

P21 series maintenance manual V1.1

Contents

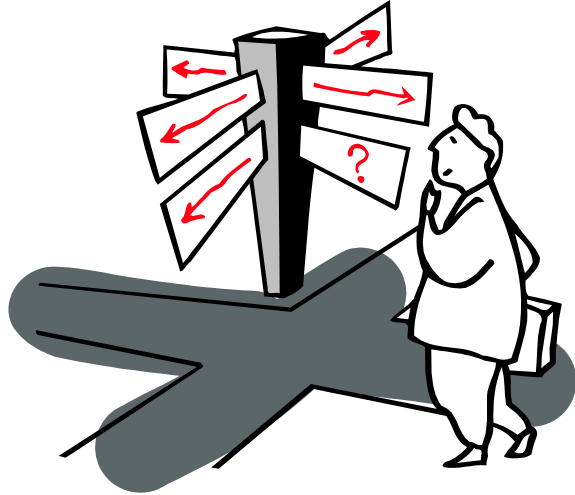

1

P21 series product appearance description

2

P21 series removing housing and PCB board screws

3

P21 series schematic diagram description

4

P21 series fault overhaul method (Visual observation, Multimeter measurement method)

5

P21 series operation of replacing defective components

6

P21 series functional test judgment method

7

P21 series whole machine assembly

P21 series product appearance description

《1》

1 PSU appearance:
(G1262/3600W, The
output voltage can be
adjusted by IIC)

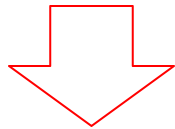

P21 series removing shell and PCB board screws

《2》

2.1 First check whether the psu is good. (confirmed by power on separately.)

2.2 PSU housing removal:

First remove the housing retaining screw
(A total of 8)

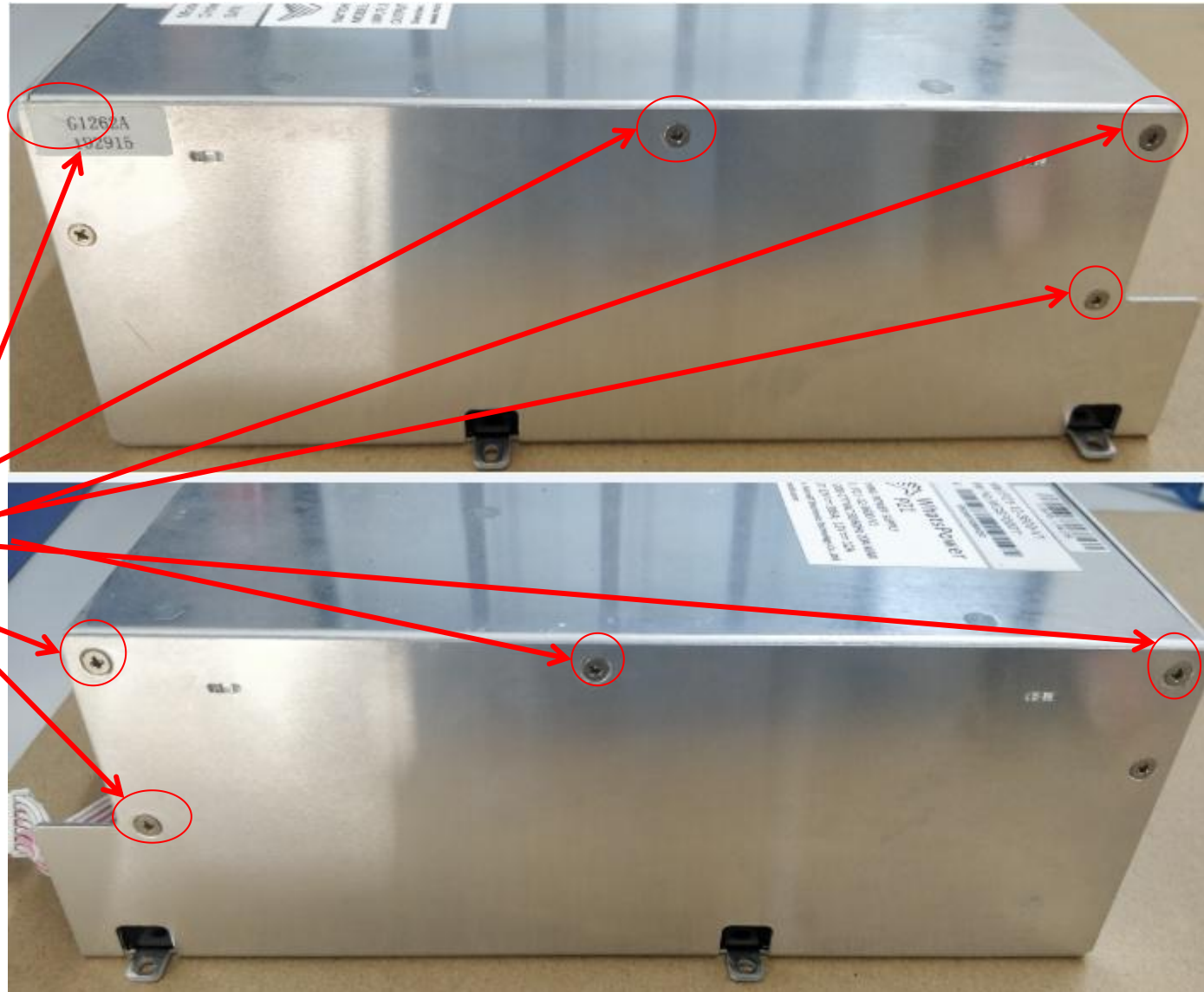
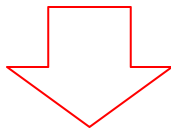

P21 series removing housing and PCB board screws

2.3 PSU disassemble:

Remove the lines on J30, CN3 and J15 before separating the upper and lower plates. show the pic:

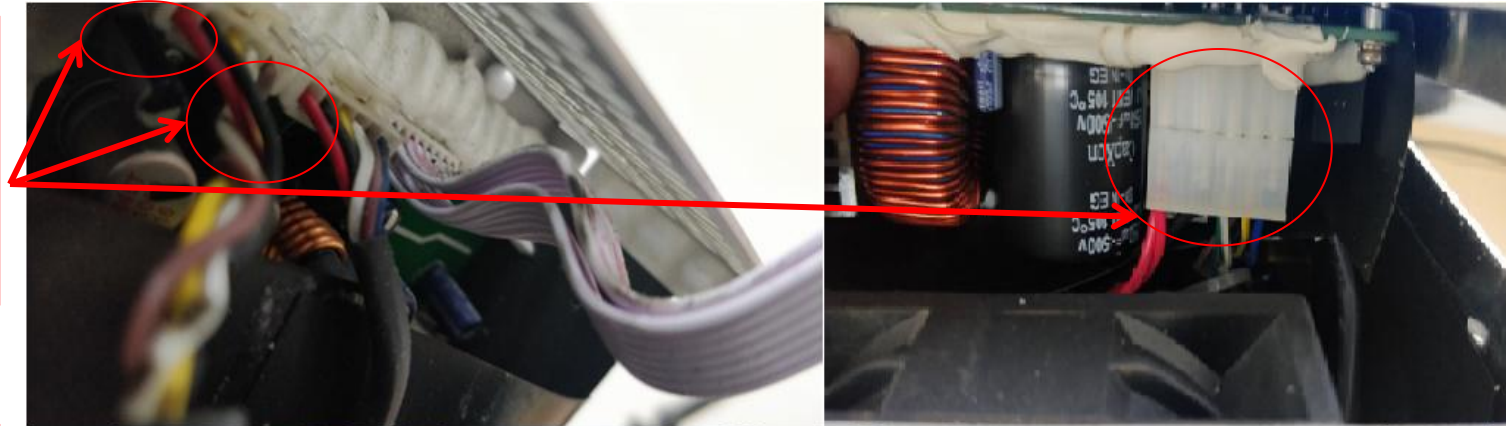

First disassemble the wire, then separate the upper and lower plates, and finally remove the screws. (There are 5 upper and lower boards, a total of 10) Remove the PCB

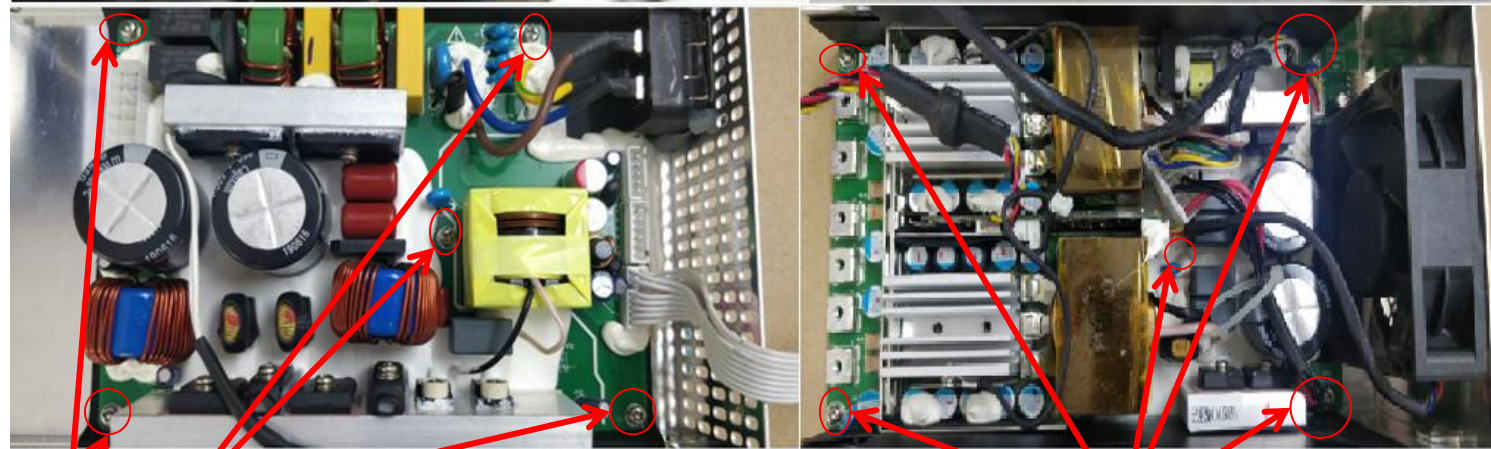

Upper plate screw

Lower plate screw

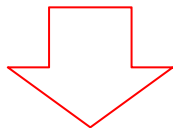

P21 series removing housing and PCB board screws

2.4 P21
PCB distinction :

PCB1 plug-in
surface

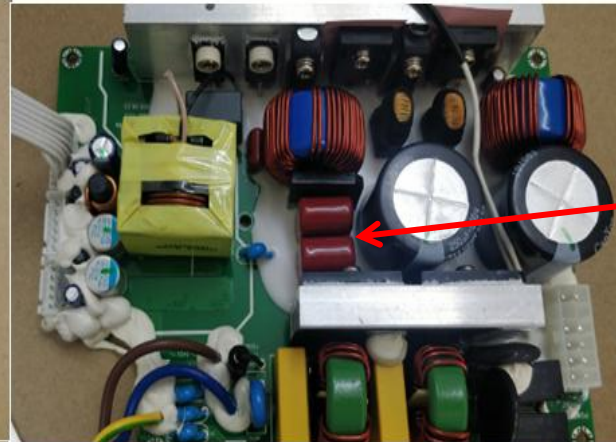
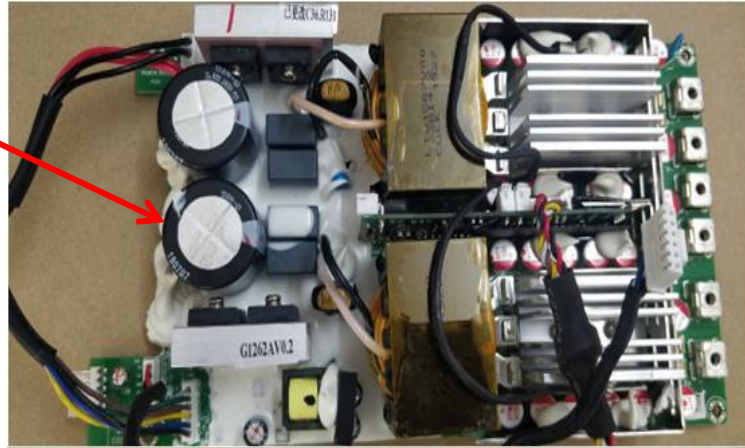

PCB2
plug-in
surface

PCB1 SMT
component
surface/Tin
surface

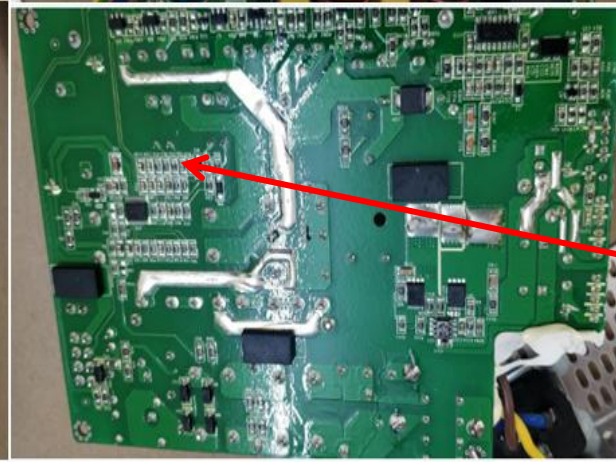
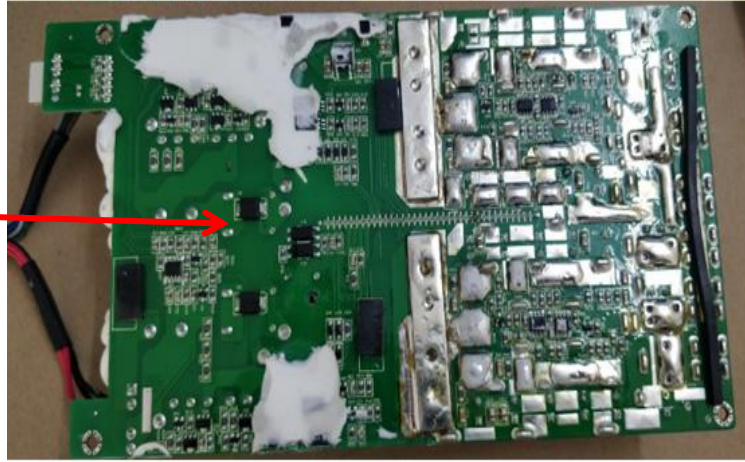

SMT
component
surface/Tin
surface

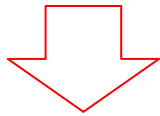

P21D/E series product appearance description

2.5 PSU appearance:
(G1291/3600W, The
output voltage can be
adjusted by IIC)

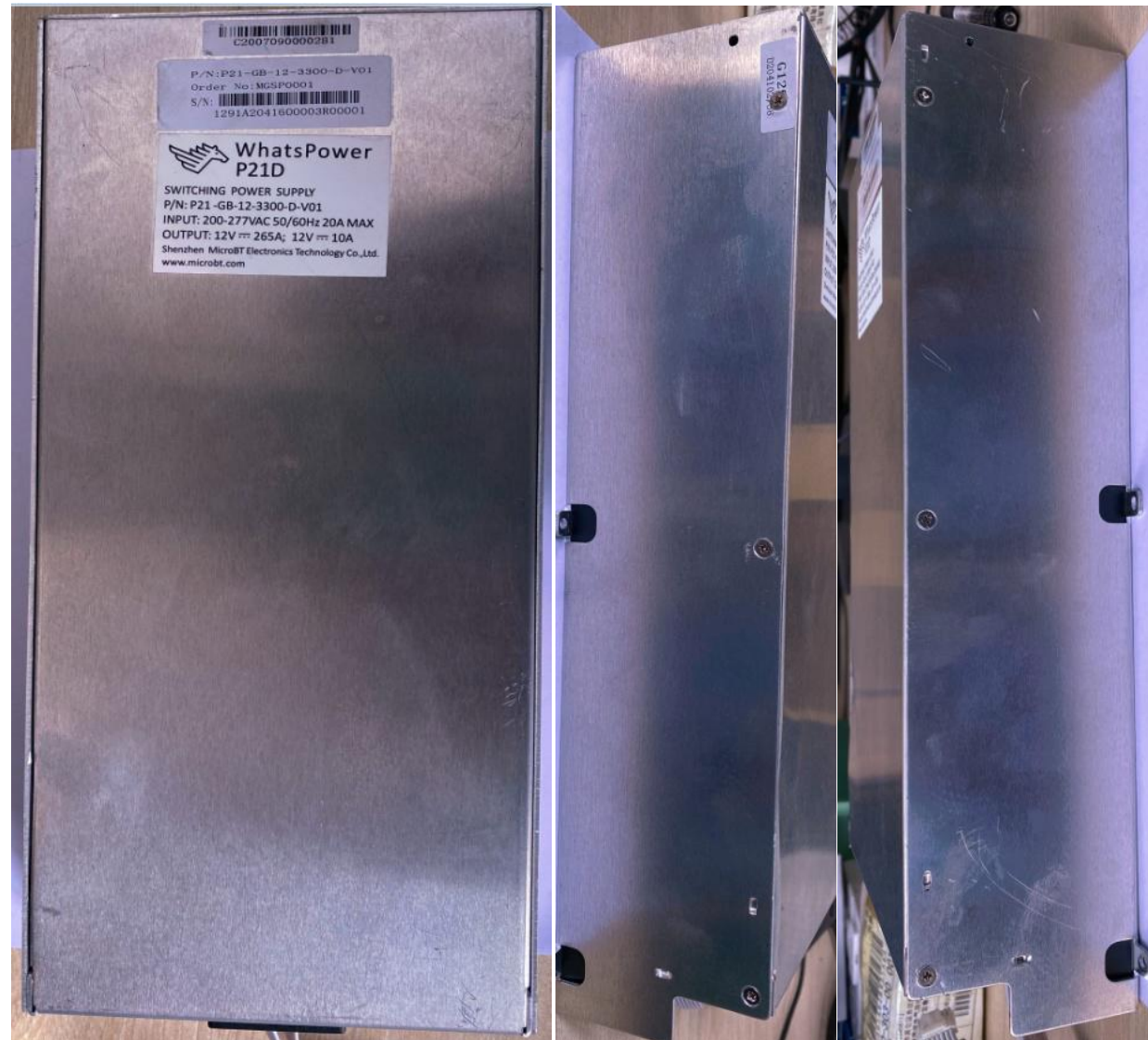
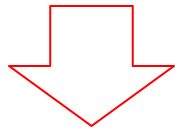

P21D/E series removing housing and PCB board screws

2.6 First judge whether the psu is good or bad.
(confirmed by power on separately)
2.7 PSU housing removal:

First remove the housing retaining screw
(A total of 6)

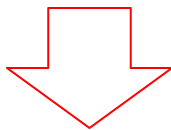
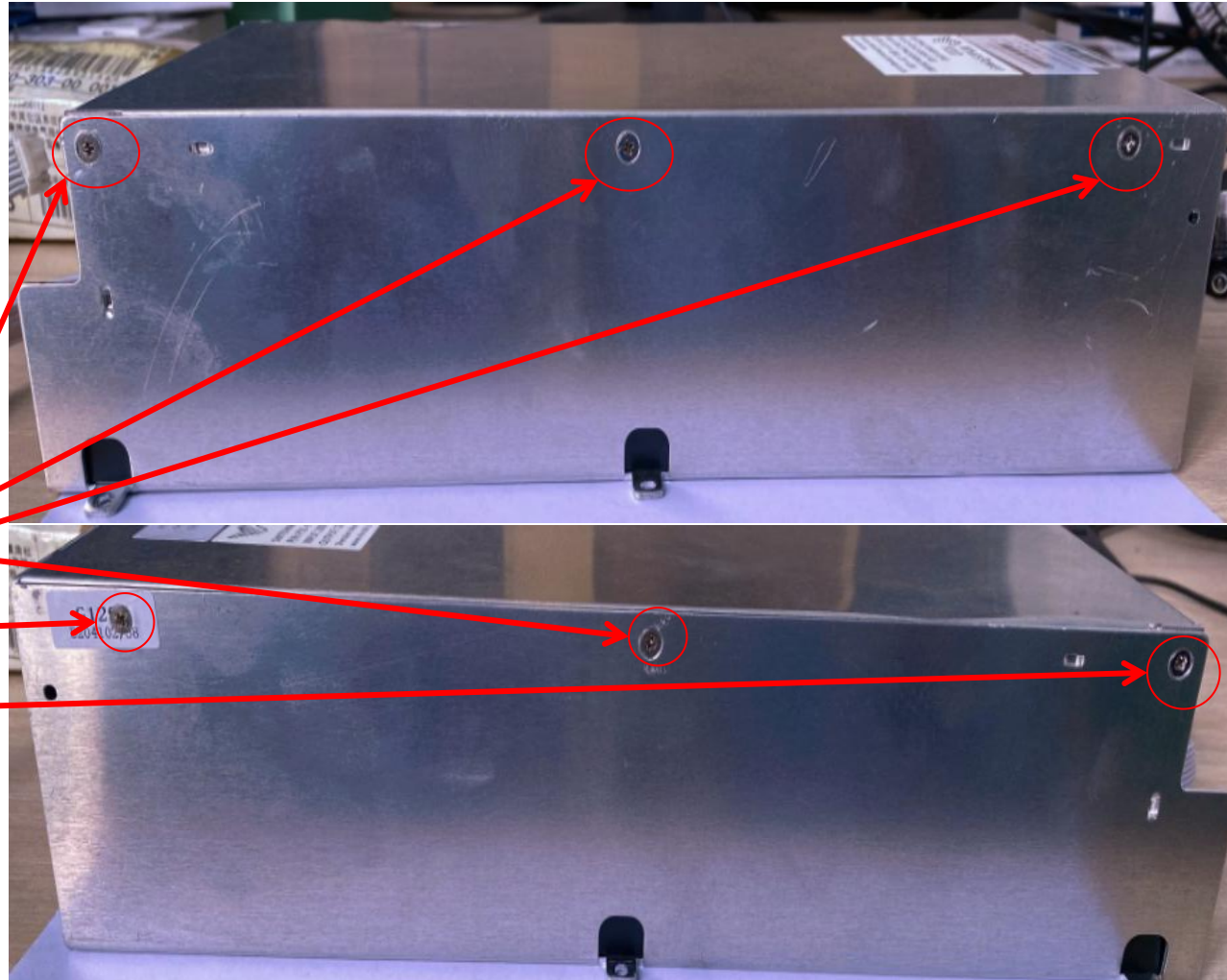

P21D/E series removes shell and PCB board screw

2.8 PSU disassemble:

Disconnect the fan socket cable before separating the upper and lower plates show the pic:

Remove the cable, then separate the upper and lower plate, finally remove 5 screws and remove the PCB.

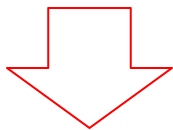
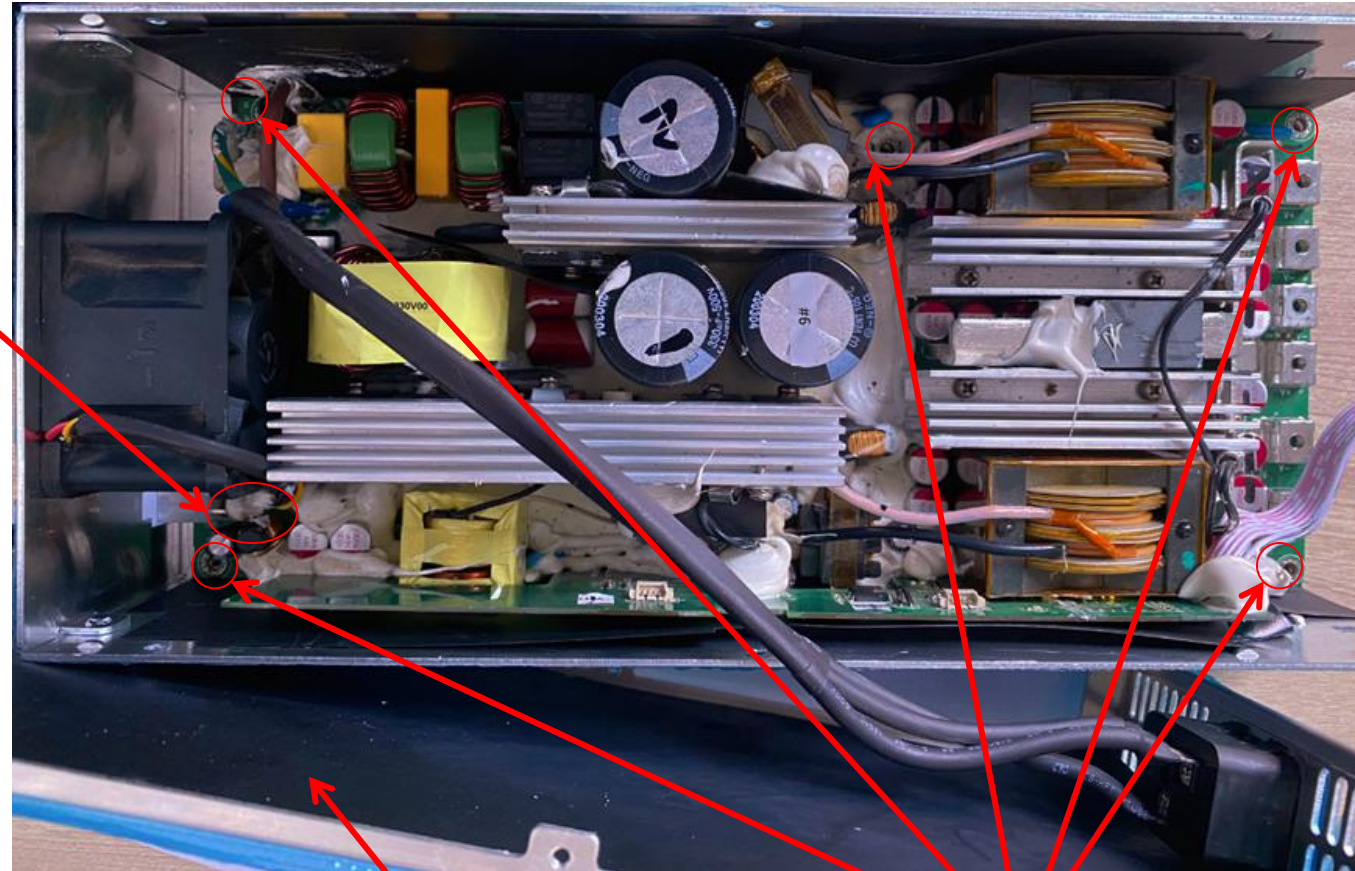

PSU machine shell

PCB screw

P21 series schematic diagram description

《3》
3.1 Block diagram of switching power supply:

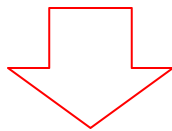
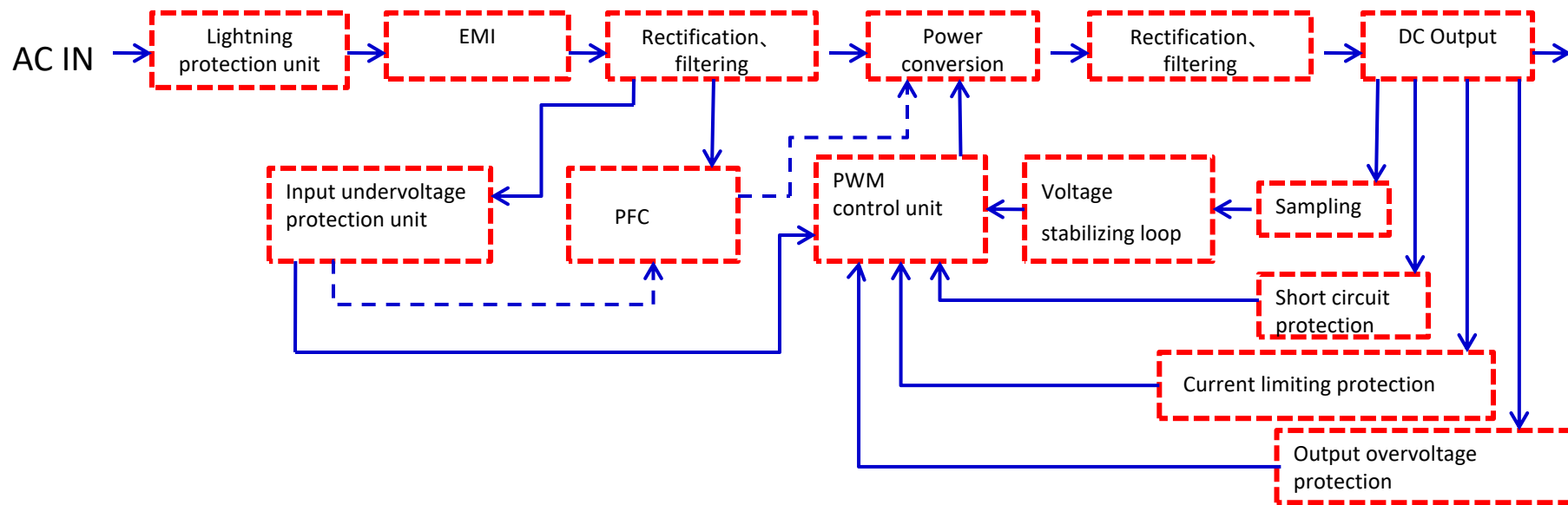

P21 series schematic diagram description

3.2 P21 circuit schematic diagram:

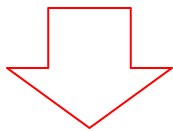
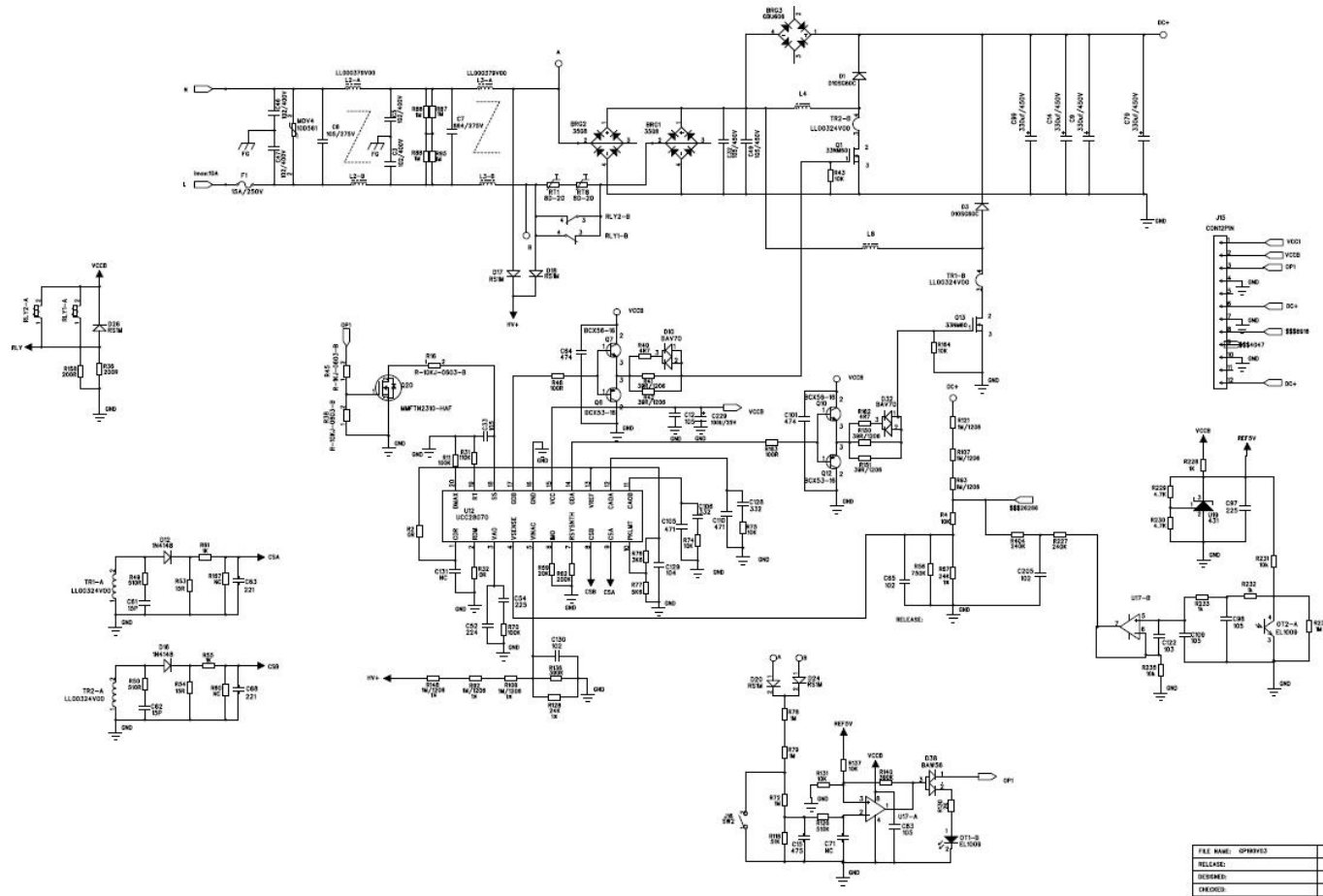

FILE NAME:	01000103
RELEASE:	
DESIGNED:	
CHECKED:	

P21 common defects description

3.3 P21 series return repair failure is classified as follows:

Number	NG phenomenon	NG reason	Component type	Point position
1、	No output	PFC circuit fault	F1、MOS、Main control chip	F1、Q13、Q1、Q7、Q8、Q10、Q12、D1、D3、U12、
2、	Voltage cannot be calibrated	Re-burn the product software and re-calibrate the voltage and current	Product software	Version: G1262V16-102215.009
3、	Communication error	The environment is bad, the DSP board is damaged, and the communication wire is damaged	Communication wire, DSP chip	J28、U37
4、	PSU is powered on normally and has no output	Isolating Optocoupler failure	Optical coupling	U10、U11、U7、U27
5、	PSU is powered on normally and has no output	Overload operation output MOS damage	Synchronous rectification MOS	Q4,Q5,Q6,Q15,Q16,Q21,Q22,Q23,Q24,Q25,Q26,Q29、
6、	Poor terminal of output line	The terminal of the output wire is damaged and the contact of the output wire is poor	Output wire and terminal	J15、J17、J16、J13、J3、J18
7、	PSU explosion	The strong electric position inside the power supply adheres to the dust, which leads to the explosion caused by the insufficient safe distance of the MOS tube	F1、MOS、Main control chip、PCBA	F1、Q13、Q1、Q7、Q8、Q10、Q12、D1、D3、U13、U9、Q30、Q33、Q20、Q21

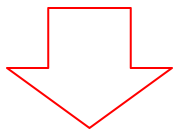

P21 failure maintenance method (Visual observation method)

Fan12VMOSTubeQ27、Q28

《4》

4.1 PCB Visual observation method :

First visual observation (PCB2) electronic component side (MOS tube、Fuse、Capacitance、Transformer) Point : RLY1/RLY2、RT1/RT2、D1/D3、Q1/Q13、Q27/Q28、F1、C14/C99、 Whether the PCBA and the components have burnt marks, as shown on the right

PFC high voltage rectifier diode D1、D3

PFC current sampling transformer TR1、TR4

F1 Fuse

Soft start thermistor RT1、RT2

Soft start relay RLY1、RLY2

PFC mos tube Q1、Q13

Filter capacitor C14、C99

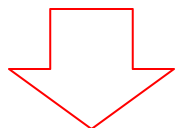
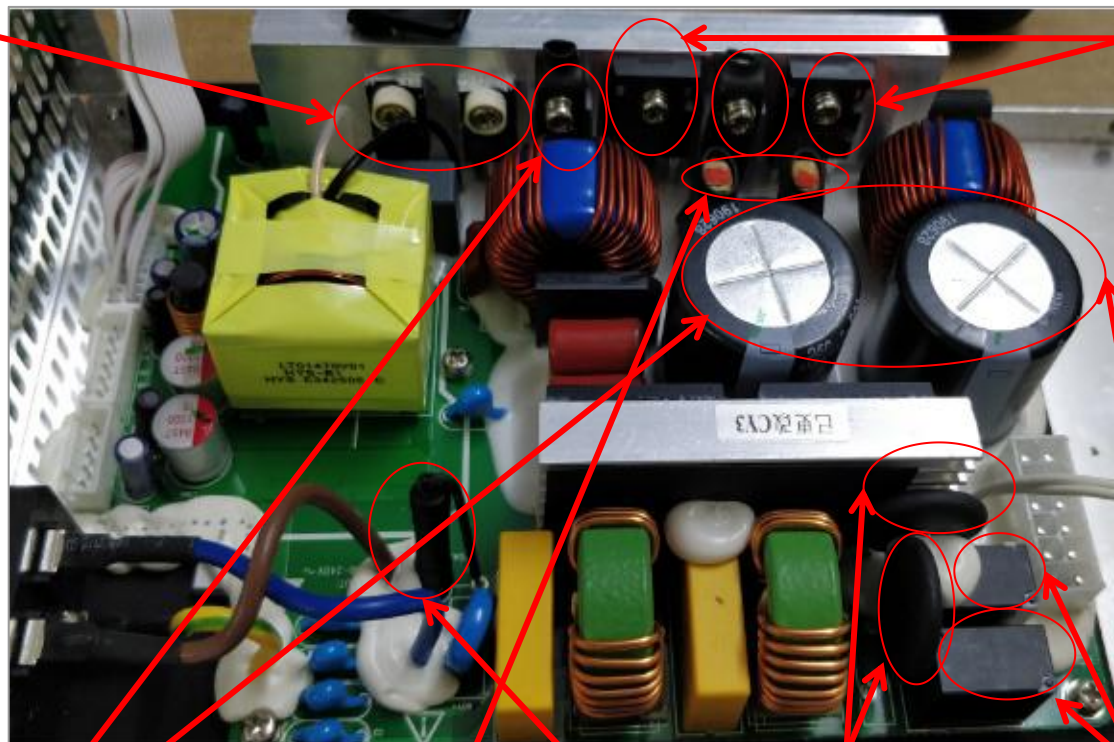

P21 failure maintenance method (Visual observation method)

SMT component surface

4.2 PCB Visual observation method :

Then visually observe the SMT/SMD component surface/tin surface for signs of electronic components burnt out or sparking with copper, as shown on the right

Q10/Q12/Q7/Q8

PFC master chip

Synchronous rectifier MOS tube

Synchronous rectifier main control chip

Side circuit 12V main control chip

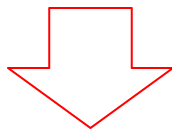
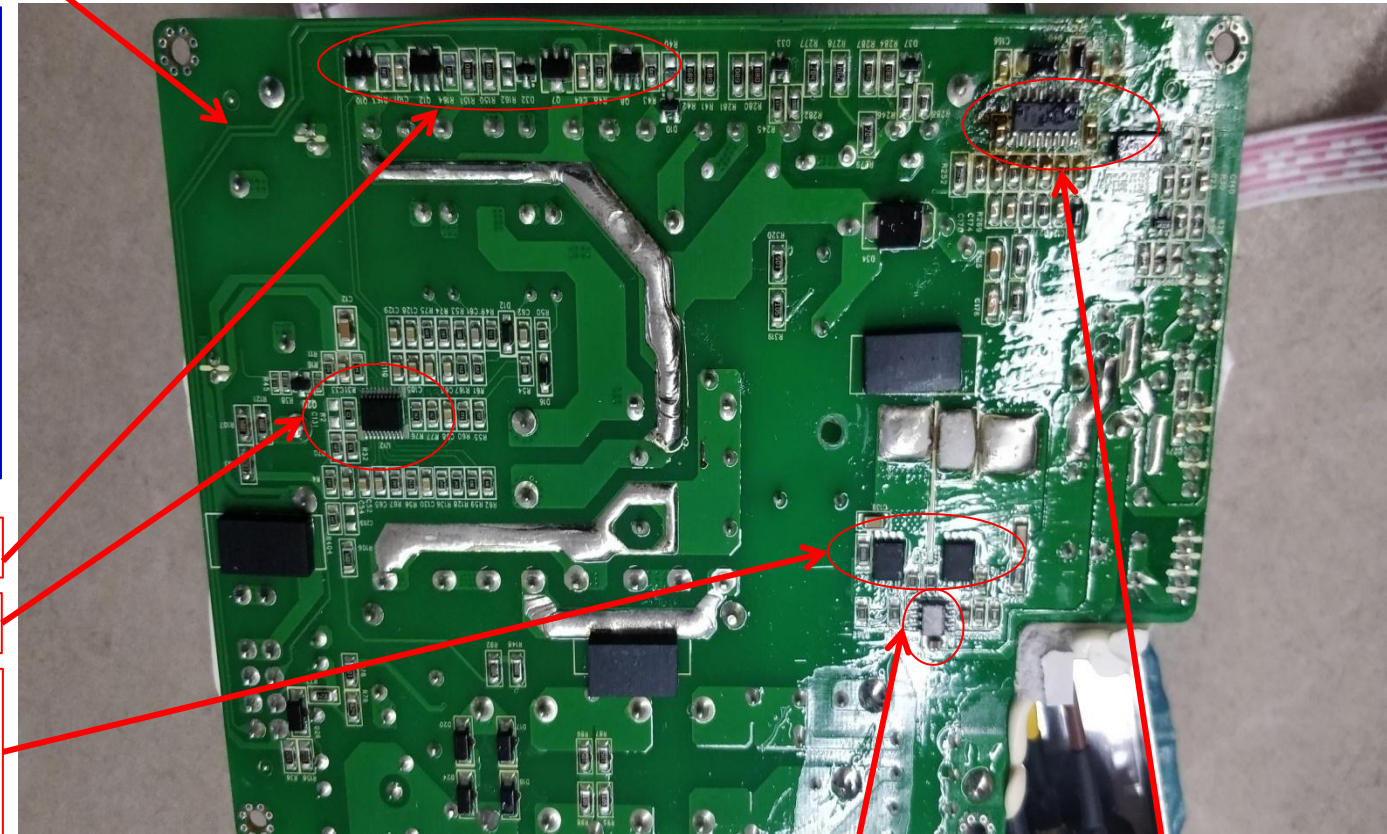

P21 failure maintenance method (Visual observation method)

4.3 PCB Visual observation method :
Then visually observe whether there are electronic components burnt out on the DIP component surface/tin surface, as shown on the right

LLC main MOS tube Q2/Q3、Q11/Q19

Main circuit current sampling transformer TR3/TR4

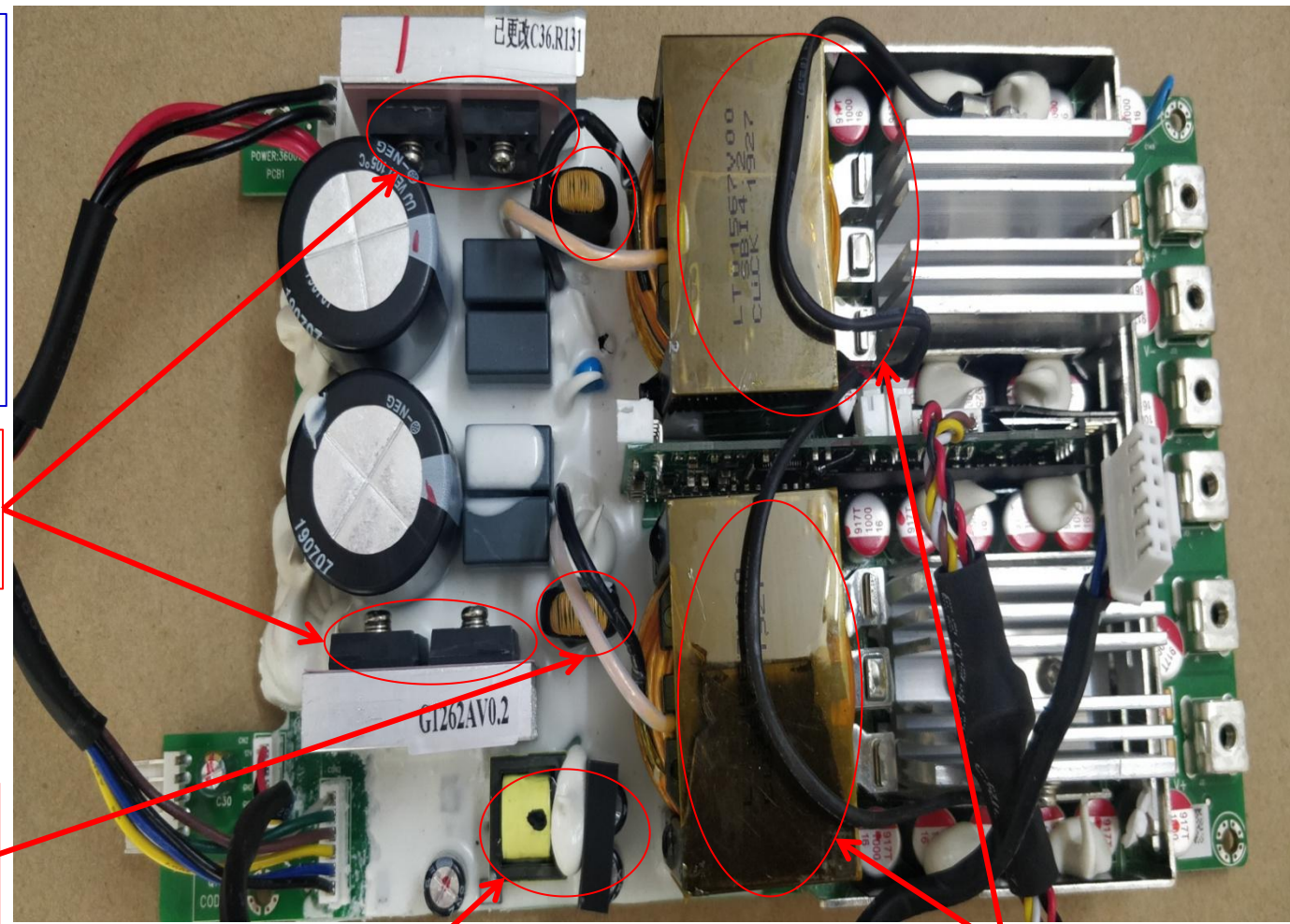
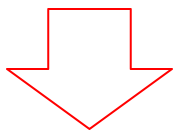

Auxiliary transformer T3

Main transformer T1/T2

P21 failure maintenance method (Visual observation method)

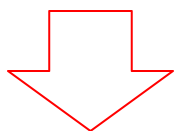
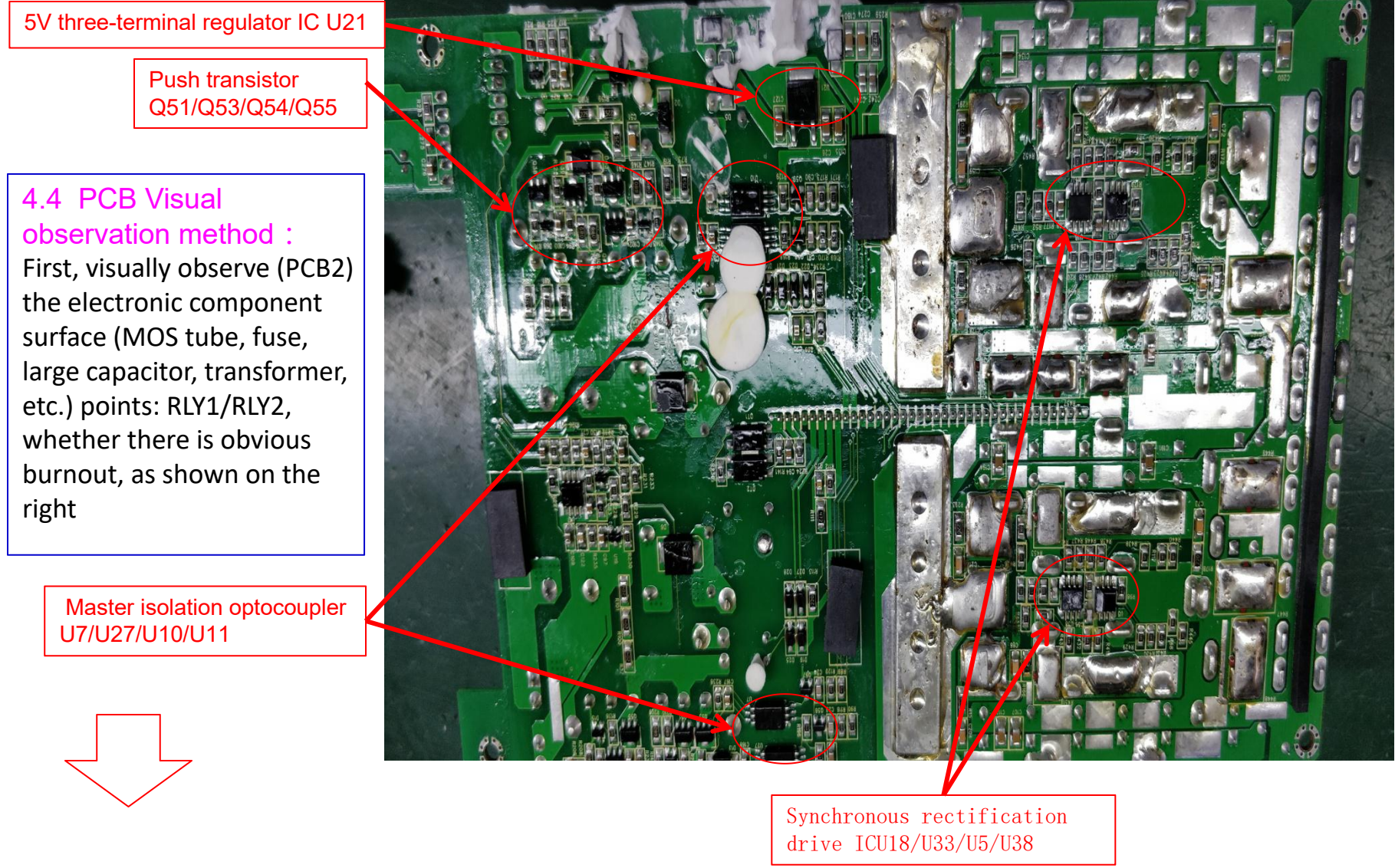

P21 failure maintenance method (Multimeter measurement method)

MOS tube diode gear
measuring range
voltage drop is normal.

4.5 PCB Multimeter measurement method:

MOS tube, rectifier bridge stack, and ordinary triode detection are measured with diode file. The voltage drop of two pins shows a range of 0.3~0.6V, indicating a good product. Otherwise, it is judged as breakdown failure. There are two measurement methods for output MOS tube (diode The minimum voltage drop of the G pole of the MOS tube is measured by the diode mode black pen to the ground red pen and the minimum is the device failure. Resistance profile measurement method Black pen to ground and red pen respectively measure the G pole resistance of the SR tube with the smallest resistance and the resistance below 2K Ω , the device will fail as shown on the right:

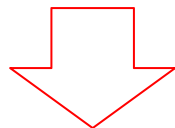
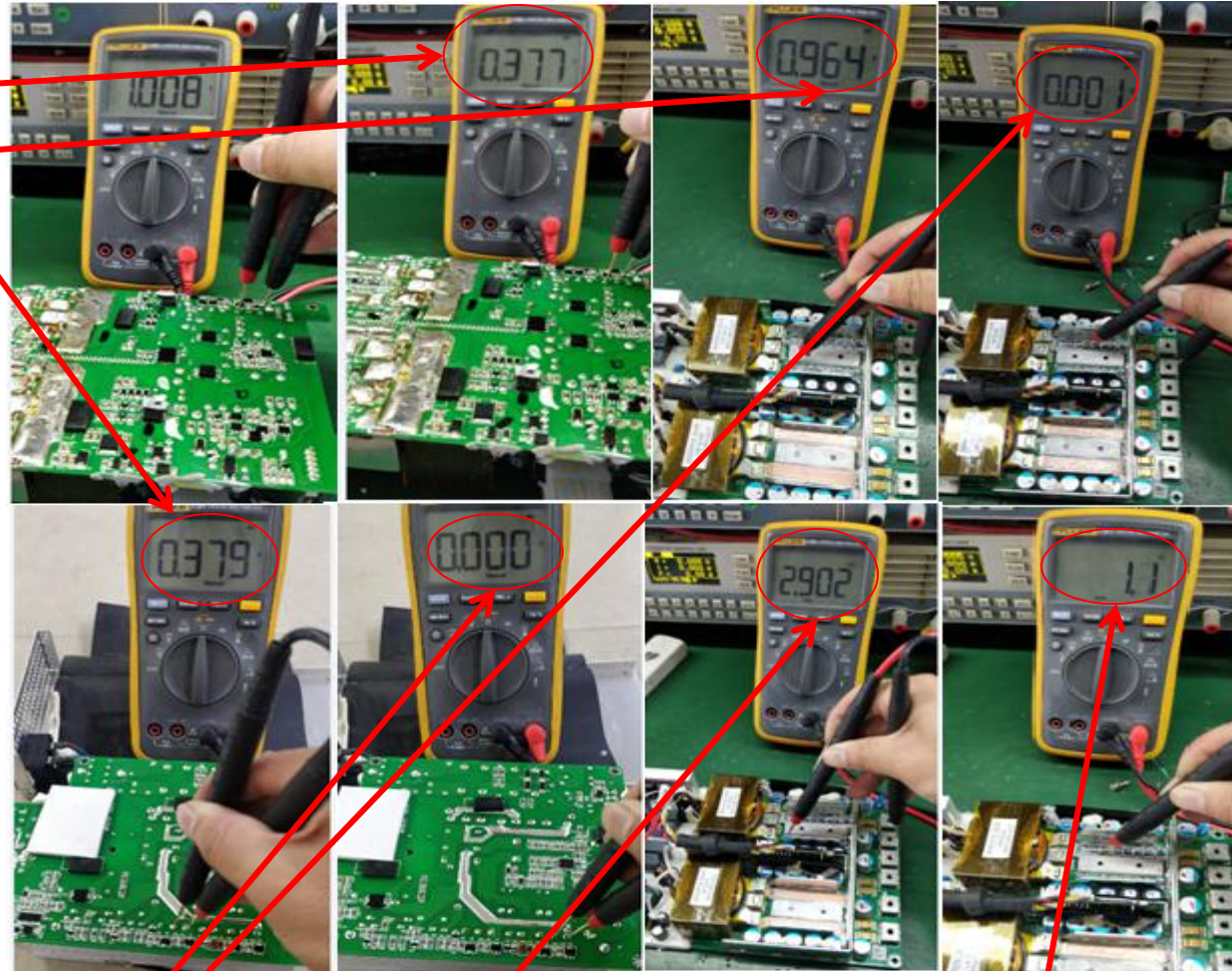

MOS tube diode gear
measuring range less than 0.
2V is a device failure

SR-MOS resistance profile
measuring resistance range 2.5
~2.9K Ω is normal

The measuring range of SR
-MOS resistance file is 1.1
 Ω for device failure

P21 failure maintenance method (Multimeter measurement method)

VCC1 voltage
range 15~18V

4.6 PCB Multimeter measurement method: First, check whether the working voltage of each group is normal. The auxiliary power circuit works VCC voltage before other circuits work. The power supply involves high voltage, so you must be cautious to operate. Non-professionals should not disassemble the machine! The voltage of each circuit is shown on the right:

VCCB voltage
range 13~16V

The voltage range after mains
rectification is 280~290V

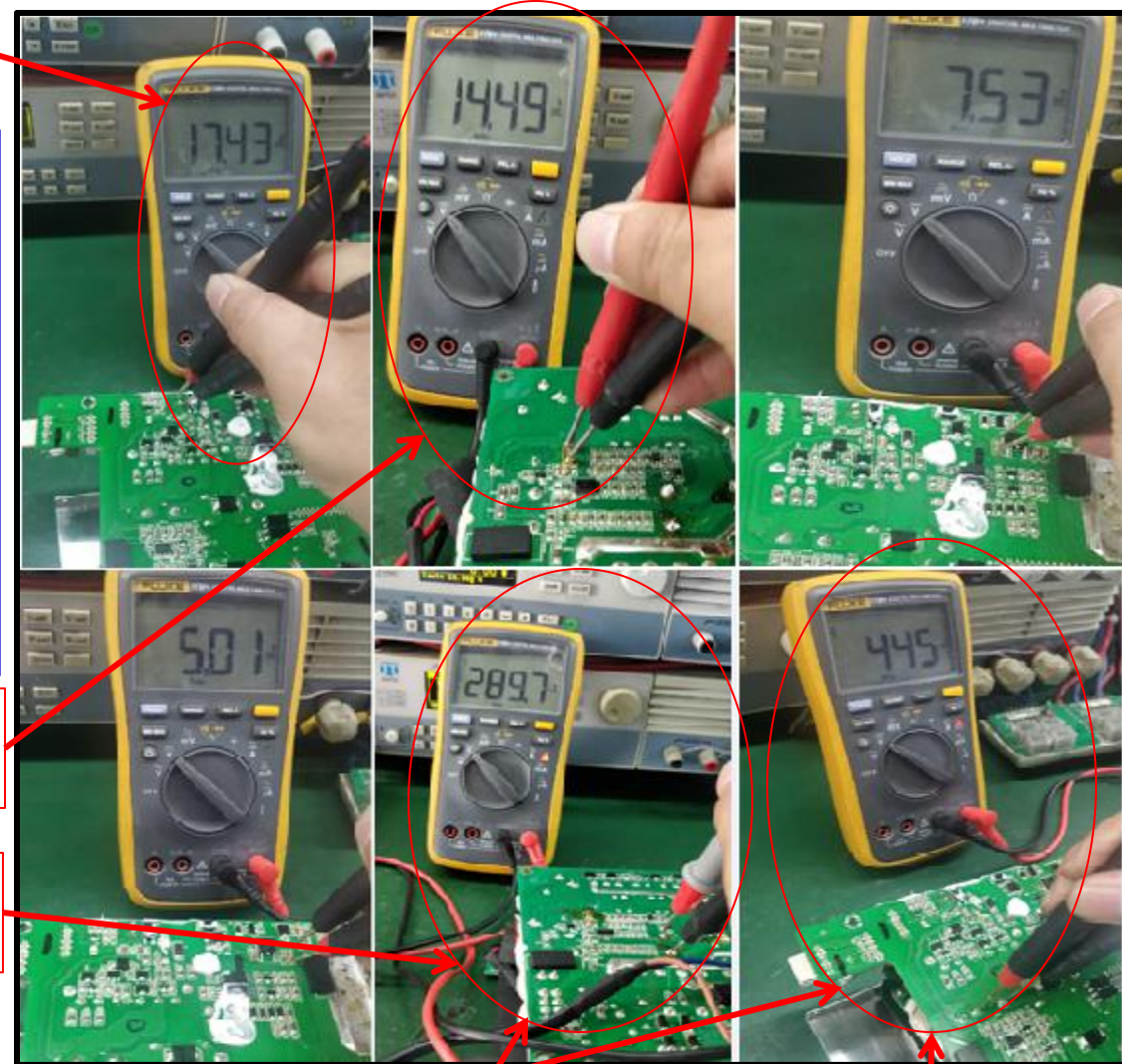
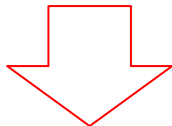

Operate carefully
with high pressure!

PFC voltage range
395~450V

P21D/E failure maintenance method (Visual observation method)

Filter capacitor C68、C23

Soft start relay RLY1、RLY2

PFC high voltage rectifier diode D4、D56

Main transformer circuit current sampling transformer

SR synchronous rectifier circuit

F1 insurance tube

4.7 PCB Visual observation method :
 First, visually observe (PCB) electronic components such as Q6/Q86/Q1/Q13
 (Are there obvious signs of burnout or sparking, as shown on the right)

PFC MOS tube Q6/Q86

LLC high voltage main transformer MOS tube Q1/Q13/Q37/Q85

High-voltage PRI control chip, the calibration parameters are written in the chip, and cannot be replaced randomly during maintenance, otherwise the calibration parameters will be cleared

Low-voltage SEC control chip, the calibration parameters are written in the chip, and cannot be replaced randomly during maintenance, otherwise the calibration parameters will be cleared

P21D/E failure maintenance method (Visual observation method)

4.8 PCB multimeter testing method:

First check whether the working voltage of each group is normal. The auxiliary power circuit will work at VCC voltage before other circuits will work. The power supply involves high voltage, so please operate with caution. Non-professionals should not disassemble the machine!

Note:

1. The schematic diagram of the P21D power supply series is basically the same as the P21 power supply. Please refer to the P21 power supply circuit schematic diagram.
2. The inspection and maintenance methods of P21D power supply series are the same as P21 power supply. Please refer to 4.5 PCB Multimeter Inspection Method.
3. The main control chip of the P21D power supply series cannot be replaced at will, because the power current and voltage calibration parameters are stored in the chip, the main control chip only allows the product's programming program to be upgraded, if the main control chip needs to be replaced, the power current and voltage calibration test must be done Can reach the factory standard.
4. For the power upgrade procedure, please refer to the online upgrade document (Shenma is providing corresponding online upgrade documents, and the power upgrade procedure is unified to Shenma).
5. After the repaired power supply, please use the electronic load for a full load test for 15 minutes to confirm whether the power supply function is normal (also can match the mining machine for aging test).
6. You can use the control panel V8 of Shenma mining machine (burn a special power supply unlocking program) to unlock the power supply for test load.
7. The structure of P21D power supply and P21E power supply is basically the same, but the output voltage and power are a little different (P21D is 12V, P21E is 14.5V)

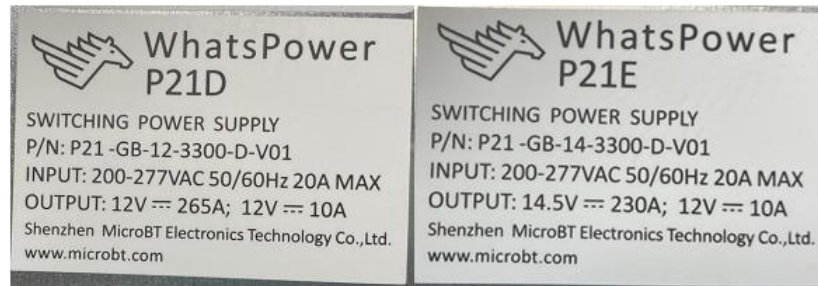
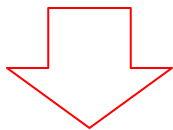

Product technical specifications

P21 supply series common fault repair materials list

4.7: Materials needed for maintenance

Component item number	Name	Specification	Point location
10115-0100012	Electronics\Relay	Single pole HF32F-G/0 12-HS 12V 10A	RLY1, RLY2
10107-1010850	Electronics\IC	SMD standard STM32F334R8T6 LQFP64 ST	u37
10107-1010165	Electronics\IC	SMD standard SI826 1BBD-C-ISR SDIP6 SILICONLABS	U7, U27, U10, U11,
10111-0220003	Electronics\Fuse	Glass tube L5F20A 250V Φ 5.5*21mm Quick disconnect with lead Languang	F1
10105-2030025	Electronics\Diode	DIP Rectifier bridge GBU608 800V 6A GBU	BRG3
10101-2059019	Electronics\resistance	DIP Thermal 8D-20 \pm 20% Foot pitch10mm Short feet	RT1, RT8
10105-2030023	Electronics\Diode	DIP Rectifier bridge GBJ3510 1000V 35A GBJ	BRG1, BRG2
10105-2050019	Electronics\Diode	DIP Silicon carbide MSP10065V1 650V 10A TO-220-2 Iron seal Maplesemi	D1, D3
10106-1010032	Electronics\Triode	SMD Triode BCX53-16 SOT-89	Q8, Q12
10106-1010033	Electronics\Triode	SMD Triode BCX56-16 SOT-89	Q7, Q10
10106-2020245	Electronics\Triode	DIP N-MOS tube OSG65R069HSF 650V 53A 69m Ω 30V 150 $^{\circ}$ C TO-247	Q1, Q13
10106-2020094	Electronics\Triode	DIP MOS tube STW48N60DM2 600V 40A TO-247 ST	Q2, Q3, Q11, Q19
10106-1020125	Electronics\Triode	SMD MOS tube NTMFS5C430NL 45V 200A DFN5 ONRds=0.0015 Ω	Q4, Q5, Q6, Q15, Q16, Q21, Q22, Q23, Q24, Q25, Q26, Q29,

P21 supply series replace bad components operation

《5》
5.1Tool
instructions:
Tin suction
device,
screwdriver,
diagonal pliers



Diagonal pliers

Tin sucker,
screwdriver

Multimeter
FLUKE17B

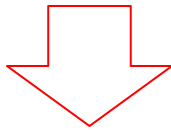

P21 supply series replace bad components operation

5.2 Tool instructions:

Constant temperature soldering iron:

1) Replace MOS tube components:

The high temperature soldering iron temperature is $400 \pm 10^\circ\text{C}$, and the soldering time of the component feet requires 3-4 seconds

2) Replace the chip resistor and capacitor components:

the temperature of the constant temperature soldering iron is $380 \pm 10^\circ\text{C}$, and the soldering time of the component feet requires 2-3 seconds

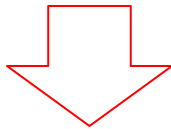

Constant temperature soldering iron: $380 \pm 10^\circ\text{C}$

High temperature soldering iron: $400 \pm 10^\circ\text{C}$

P21 supply series replace bad components operation

5.3 Change the NG MOS tube assy:

1) To determine the failure of the MOS, use a screwdriver to remove the silica gel

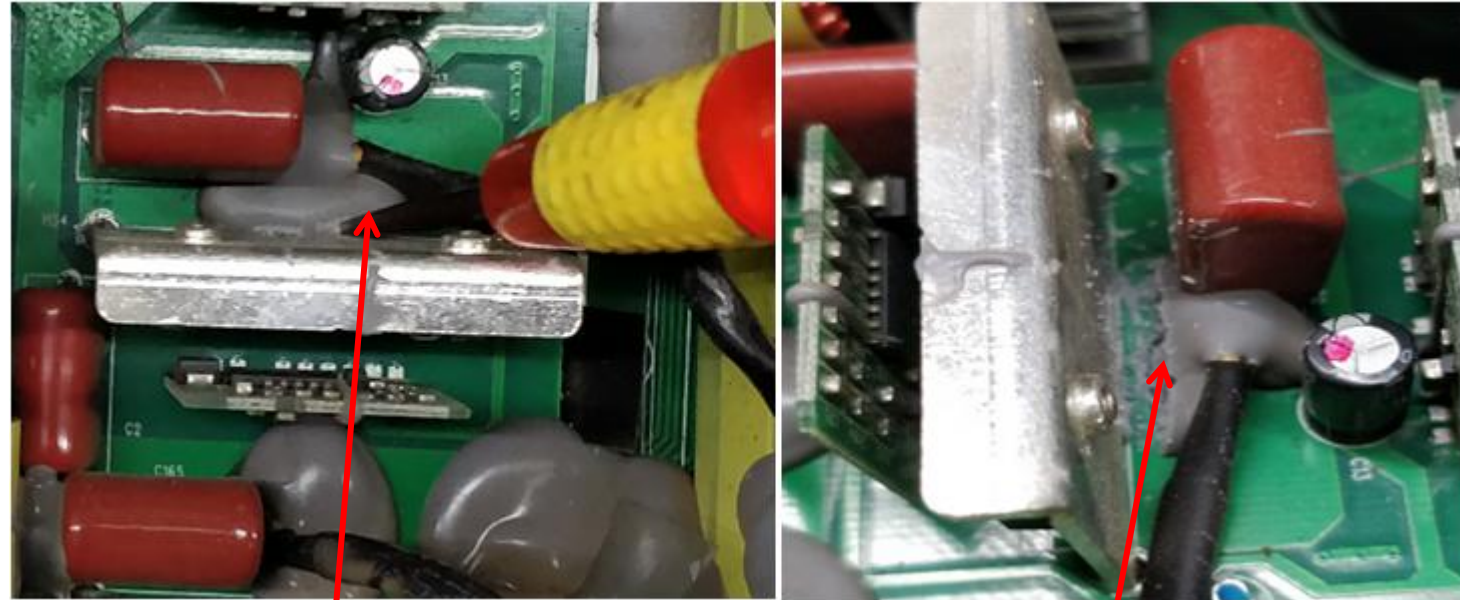
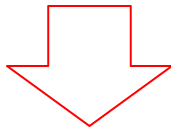

Remove the silicone with a screwdriver

State after removing silica gel

P21 supply series replace bad components operation

5.3 Change the NG MOS tube assy:

1) To determine the failure of the MOS, use a screwdriver to remove the silica gel

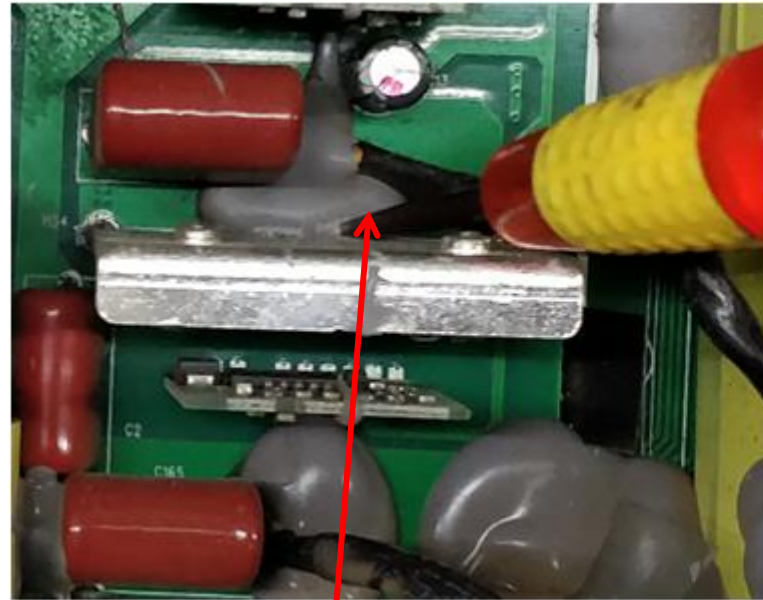
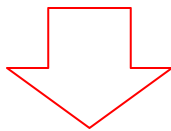

Remove the silicone with a screwdriver

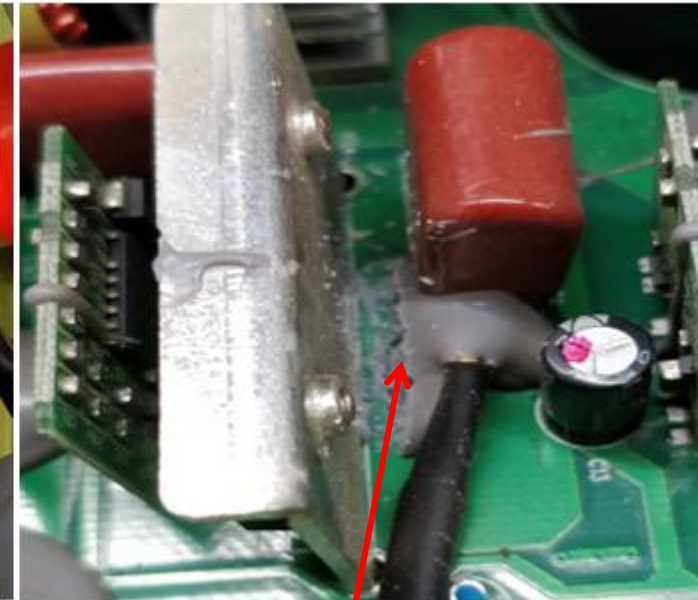

State after removing silica gel

P21 PSU series operation of replacing defective components

取出失效MOS管
Remove the failed MOS

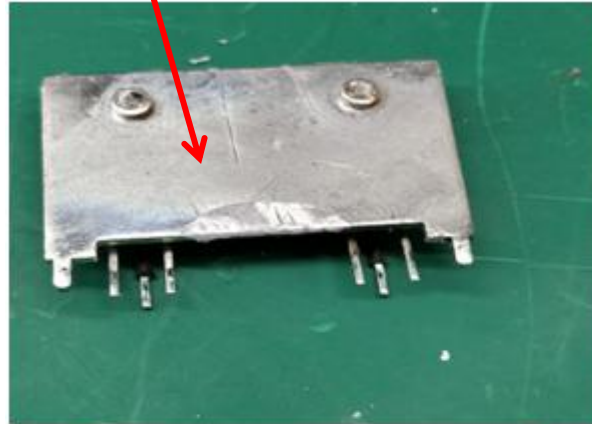

取出MOS管状态
MOS pin status after removal

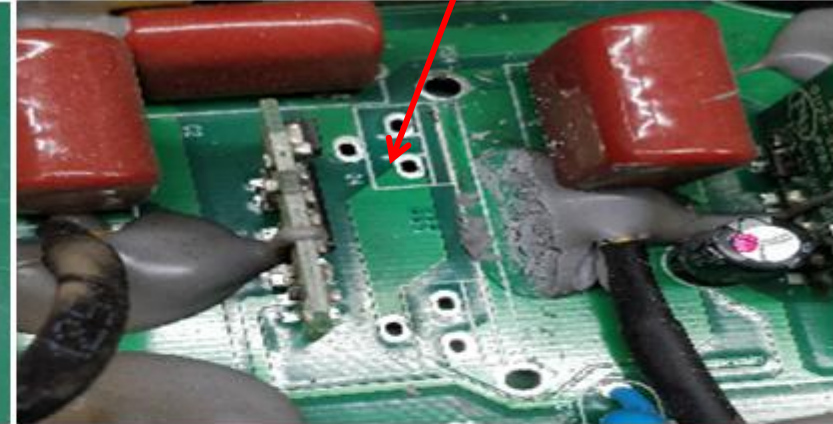

5.3. Replace MOS element
3) Remove the MOS and loosen the fixing screw with a screwdriver before taking down the MOS body

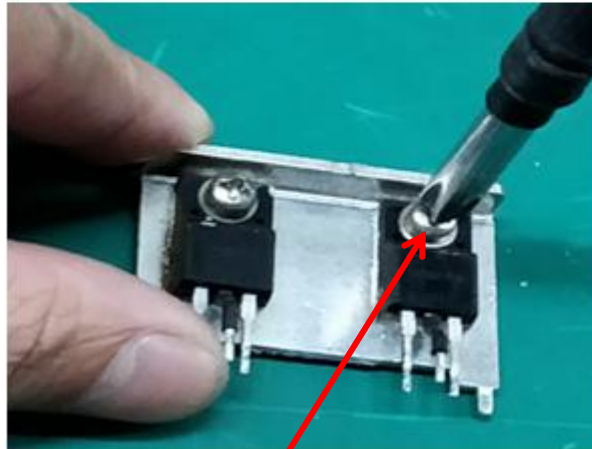
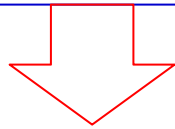

Removing the fixing screw with a screwdriver

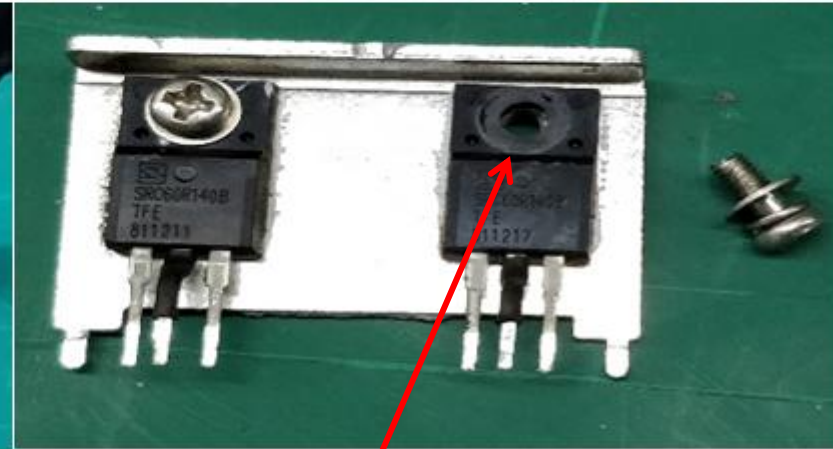

Status of removing MOS fixing screw

P21 PSU series operation of replacing defective components

Install the good MOS on the radiator and screw it
MOS assembly on PCB

MOS管组装到PCB上状态
MOS assembly on PCB

5.3. Replace MOS element
4) Assemble the good MOS and solder without false soldering

Note: other electronic components can be replaced according to the above method

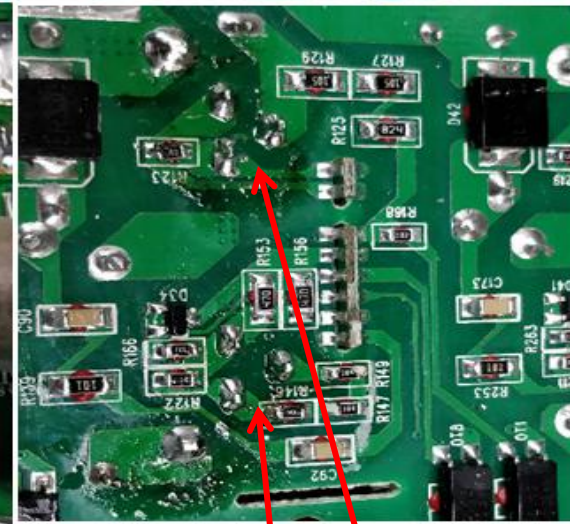
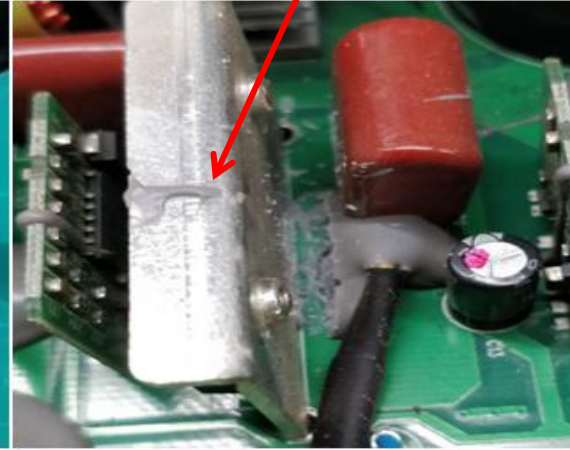
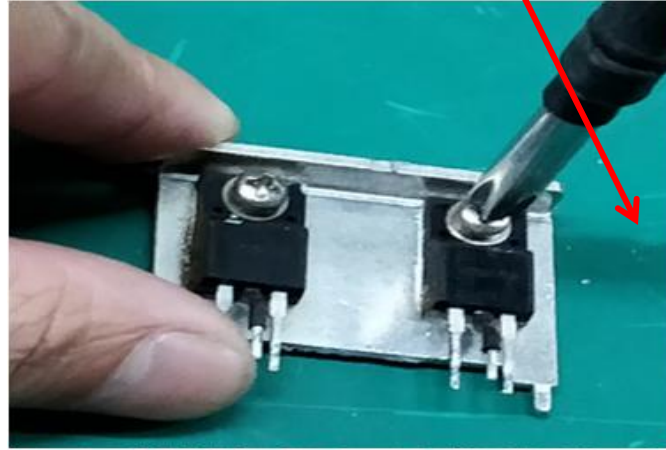

Welding MOS pin with constant temperature soldering iron

Status of soldered MOS

P21 PSU series operation of replacing defective components

Install the good MOS on the radiator and screw it
MOS assembly on PCB

MOS管组装到PCB上状态
MOS assembly on PCB

5.3. Replace MOS element
4) Assemble the good MOS and solder without false soldering

Note: other electronic components can be replaced according to the above method

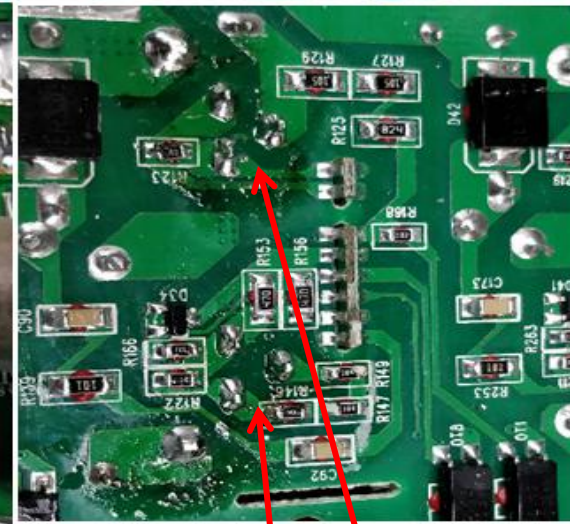
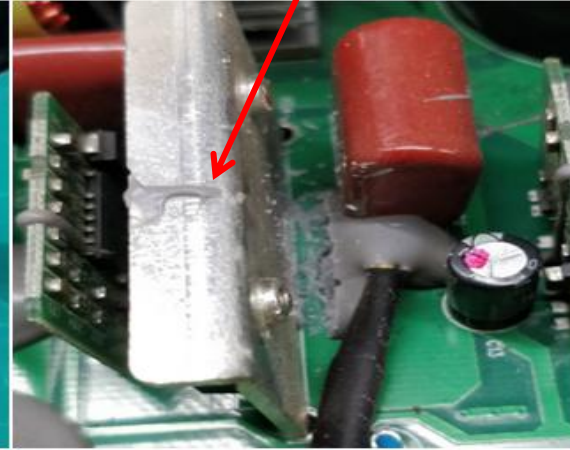
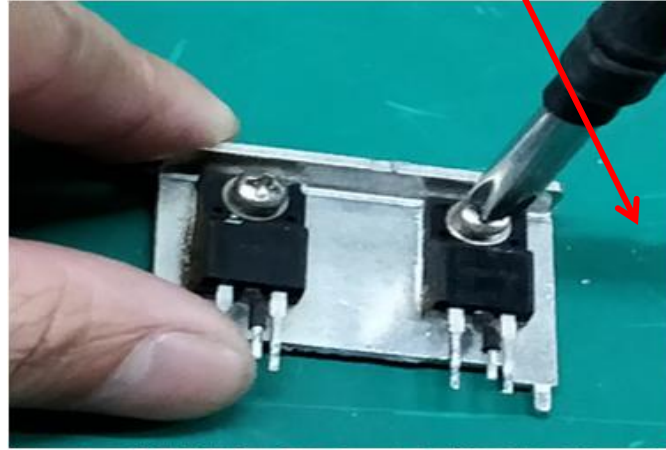

Welding MOS pin with constant temperature soldering iron

Status of soldered MOS

P21 PSU series test and judgment method

6.1 Install labview2014 software

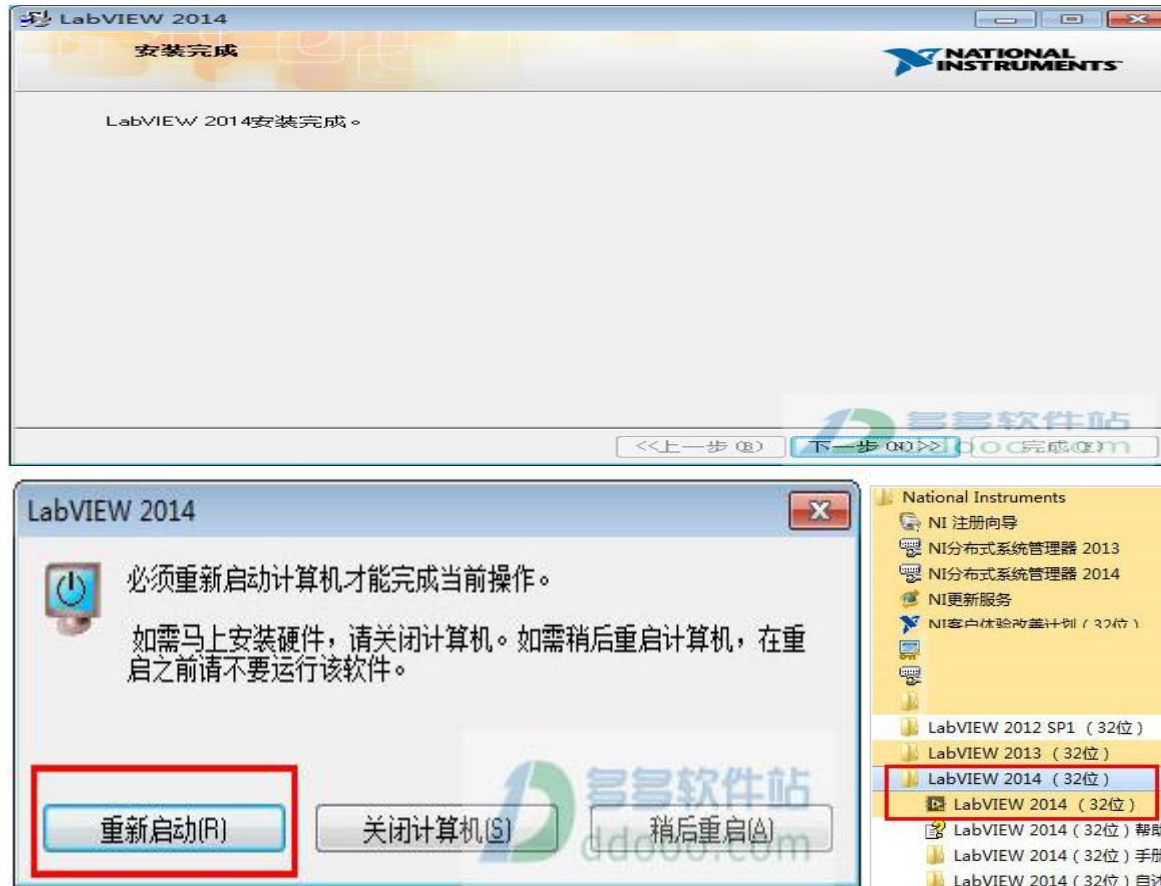

Note: according to the installation of labview2014 software tutorial, install it step by step on the computer, until the installation is completed, restart the computer to run the p21 power supply matching upper computer software; if there is no special power unlocking interface device for Gospower, the V8 control board of whatsmminer can also be used to test the power unlocking.

P21 PSU series test and judgment method

6.2 copy the upper computer software of p21 power supply (1262) into the computer and put the shortcut on the computer desktop



6.3 install labview2014 software and click the p21 power supply (1262 / 1291) software icon to run

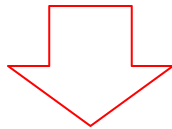

judgment method

6.4 description of p21 power supply matching upper computer software interface:

Switch on / off button: release the lock function for the product, make the voltage output normally, and the power supply will be in the lock state when the next power on.

Initialization on / off button: permanently release the lock function of the product, so that the voltage can be output normally. In the next power on, there is no need to connect and communicate with the upper computer, and the power supply will have voltage output.

Issue button: set the parameters of power supply.

Reset button: reset the parameters of the power supply.

Calibration button: calibrate the voltage and current of the power supply

Serial port selection: set the communication port between RS485 industrial converter and computer.



P21 PSU series test and judgment method

6.5 communication block diagram of p21 power supply and computer, upper computer software and power supply connection



6.6 description of upper computer software interface:

First, select the corresponding serial port for the connection and communication between the computer and the product. At this time, the RS485 device communication indicator light flashes, indicating that the computer serial port setting is completed, and then the communication with the power supply can be unlocked

Note: if the customer does not have the above equipment, it can also match the miner as the load for power on confirmation

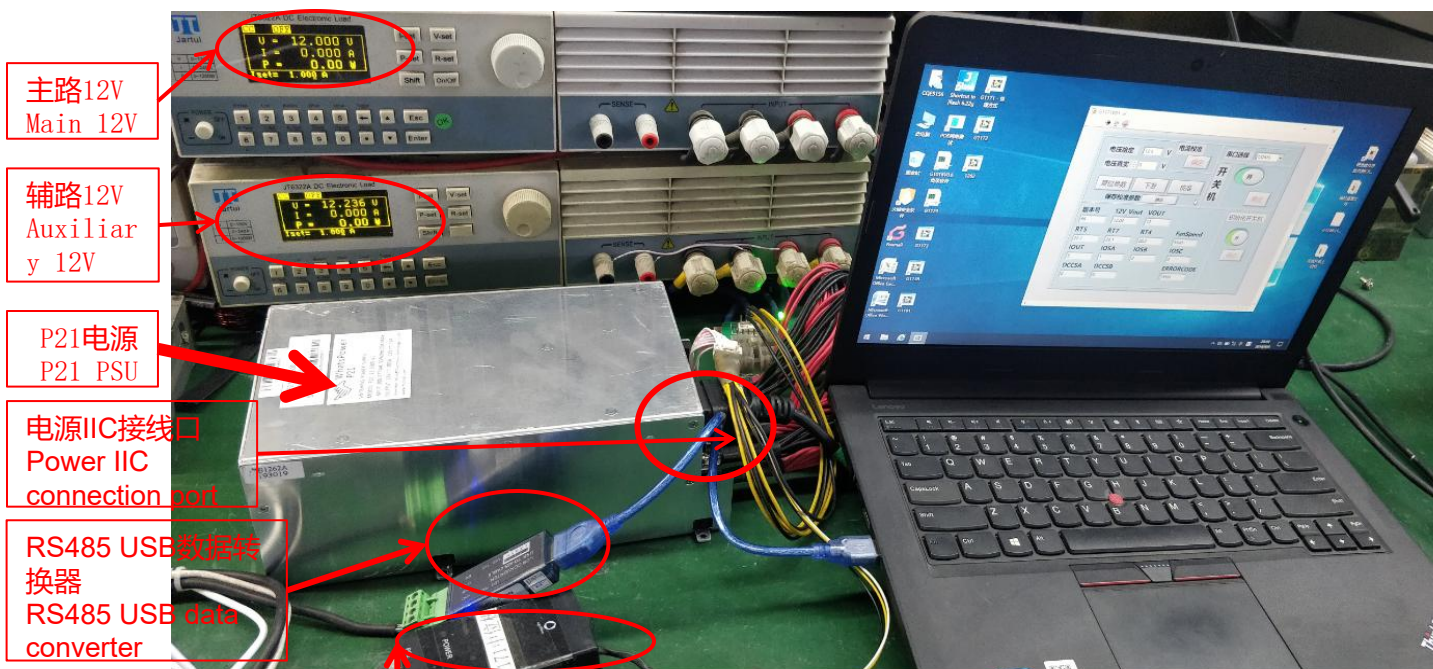

P21 PSU series test and judgment method

6.7 schematic diagram of connection between p21 power output terminal and electronic load

Connect the positive (+) and negative (-) of p21 power output terminal to the positive (+) and negative (-) power output terminals of load positive (+) and negative (-) respectively. Do not reverse the positive and negative electrodes!

Note: if the customer does not have the above equipment, it can also match the miner as the load for power on confirmation

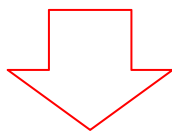

P21 PSU series test and judgment method

6.8 overall diagram of connection between p21 power output terminal and electronic load

Note: if the customer does not have the above equipment, it can also match the miner as the load for power on confirmation

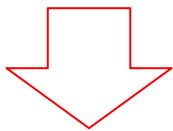

P21 PSU series test and judgment method

6.9 electronic load interface:

- load set to CC mode (cc1a)

When p21 power is on and the communication is normal, click the upper computer software on / off button to unlock. At this time, the normal output voltage of the power supply, the data displayed on the electronic load display screen and the upper computer software are at the set voltage of $12V \pm 5\%$, indicating that the power output is normal, otherwise, it is a defective product

Note: if the customer does not have the above equipment, it can also match the miner as the load for power on confirmation

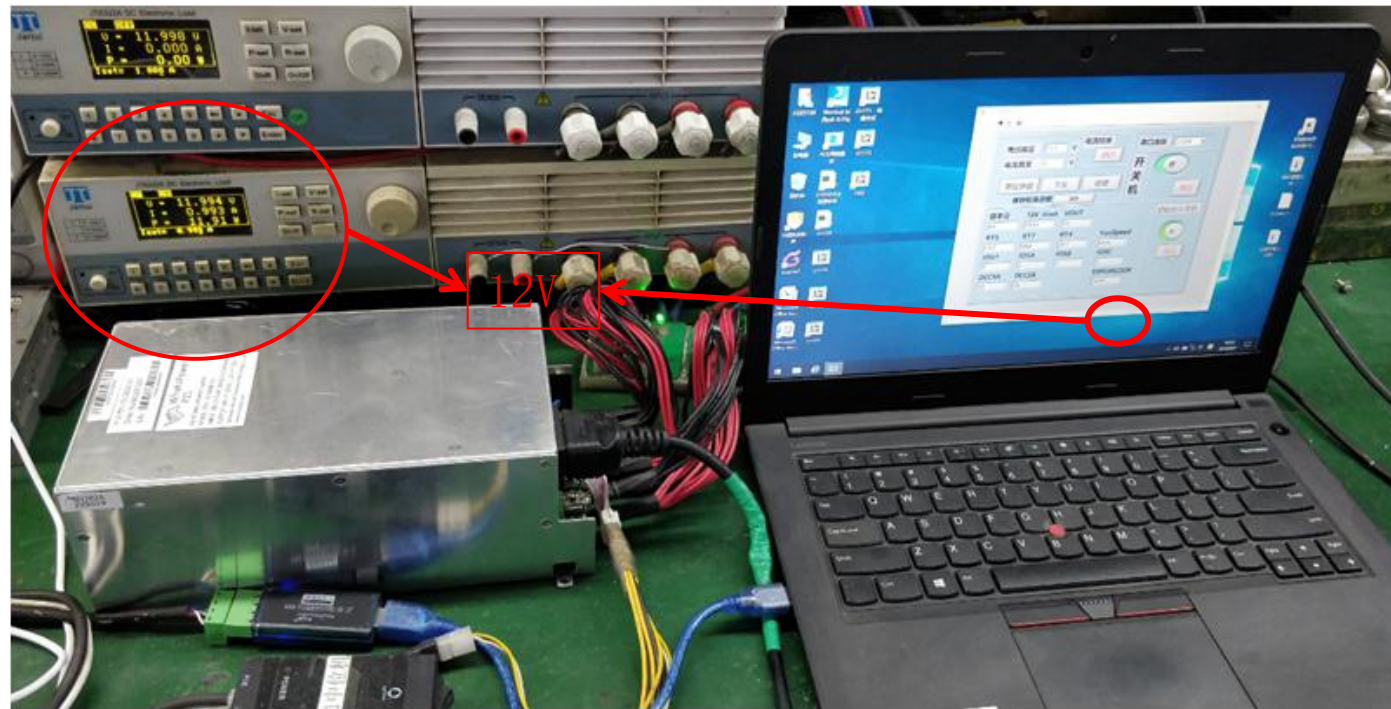

Note: p21 is an intelligent power supply, and the internal part is controlled by software. After the power supply burns the product program, the current calibration of individual power supply (about one thousandth) has some deviation, which affects the output power. Therefore, it is necessary to take full load for current calibration again to solve the problem

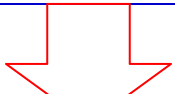

P21 PSU series function test equipment introduction

6.10: Equipment list for p21 power supply maintenance

SN	Equipment model	Specifications	QTY	Remarks
1、	Notebook computer	联想14寸笔记本电脑/Windows7	1PCS	须要安装labveiw14.0软件方可运行T2电源上位机软件 It is necessary to install labveiw14.0 software to run T2 power upper computer software
2、	电子负载 Electronic load	JT6322A/1200W	3PCS	产品输出，带载电压电流校准 Product output, on load voltage and current calibration
3、	产品接口设备 Product interface equipment	高斯宝定制设备 Customized equipment	1PCS	RS485工业转换器、定制单片机软件 RS485 industrial converter, customized MCU software
4、	AC短路电路 AC short circuit circuit	高斯宝定制设备 Customized equipment	1PCS	当产品强电部分短路时起到保护作用 It plays a protective role when the strong current part of the product is short circuited
5、	万用表 Multimeter	FLUKE 17B	1PCS	测量判断元件状态 Measuring and judging element state
6、	恒温烙铁 Constant temperature soldering iron	白光白光BK3300、白光SBK936b bk3300, sbk936b	2PCS	1PCS为高温烙铁、1PCS为恒温烙铁 1pcs is high temperature soldering iron, 1pcs is constant temperature soldering iron
7、	吸锡器 Tin suction device	DS017	1PCS	拆除失效元件 Removal of failed components
8、	Tool	斜嘴钳子、尖嘴钳子、螺丝刀107 Oblique nose pliers, pointed nose pliers, screwdrivers 107	3PCS	斜嘴钳子、尖嘴钳子、螺丝刀 Oblique nose pliers, pointed nose pliers, screwdrivers 107

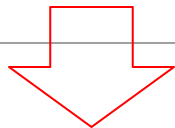

P21 PSU assembly

《7》

7. 1 After repaired the NG PSU by process above, need to check whether the cooling fin fall off from PCBA1 , Check it as right picture showing, prevent the PSU from high temperature and be protected.

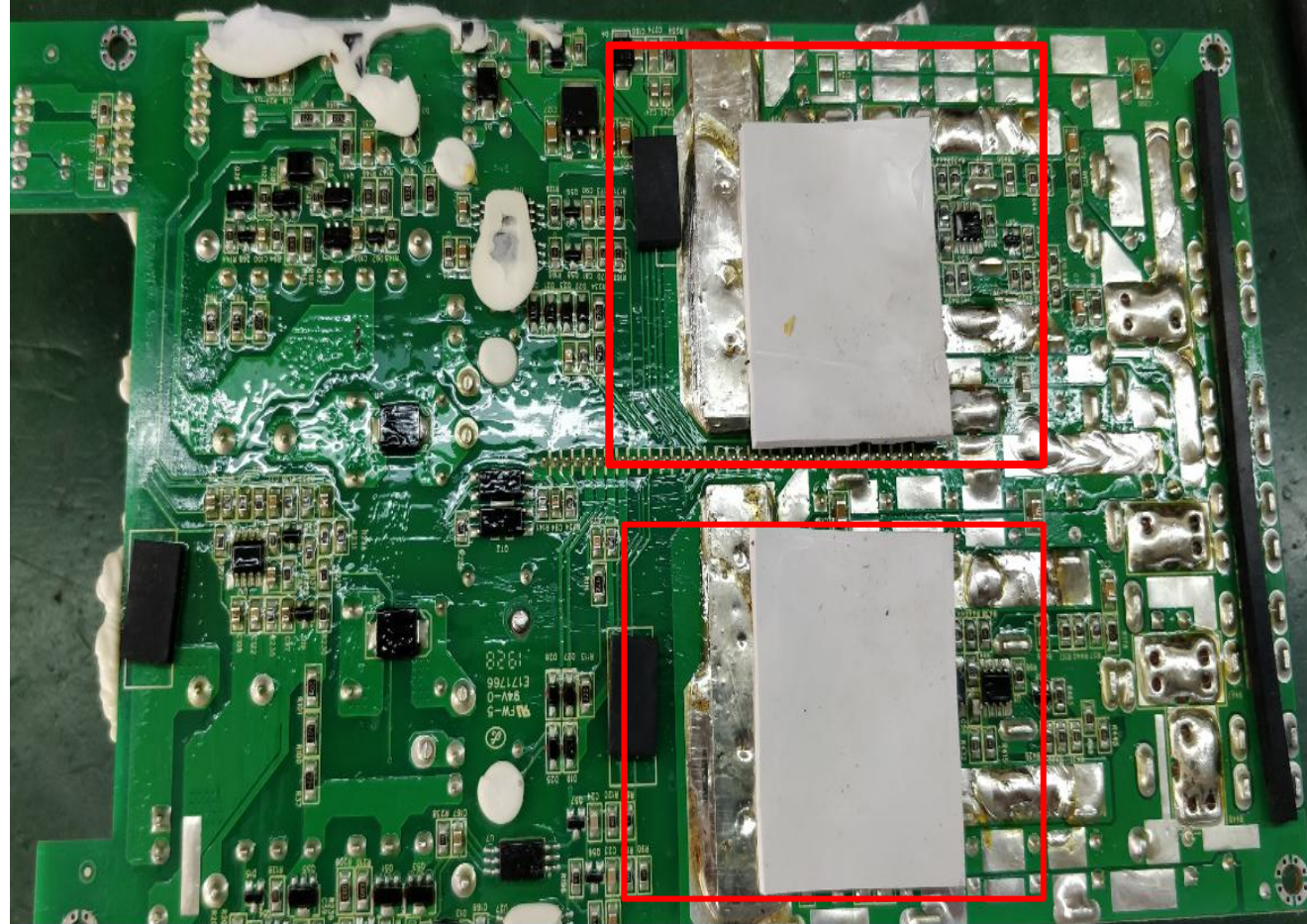
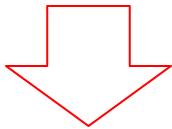

P21 PSU assembly

Install the PCB1 as the arrow direction

PCB install in location and fit with the screw hole.

7.2 Install the PCB1 to housing and lock the screws accordingly, prevent the cable from bearing the PCB as right picture showing.



Insert the PSU fan pin (fan cable should cross the hole of plastic lock)



Lock the screws in order

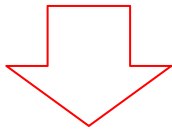

P21 PSU assembly

7.3 Lock the PCB2 in the housing with 5 screws in order, prevent the cable from bearing the PCB as right picture showing.

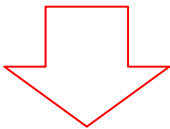

Notice the location of the silica pad!



Aim at the screw hole as showing.

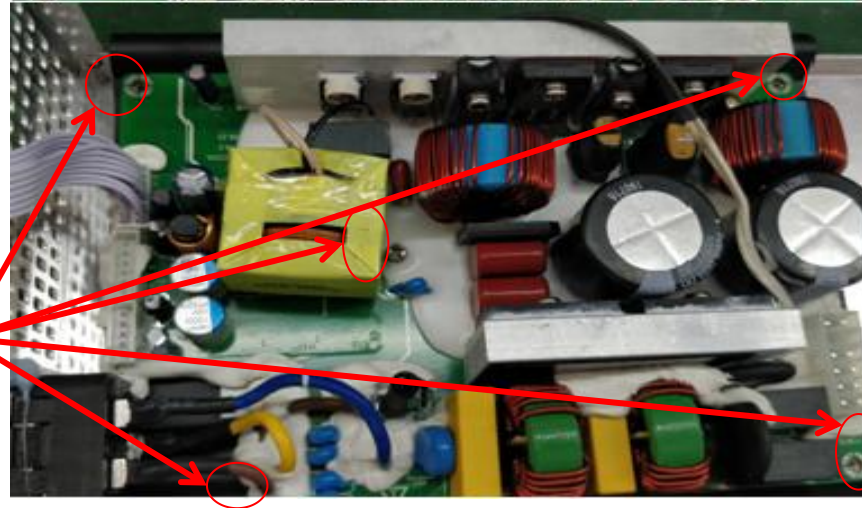

P21 PSU assembly

7.4

Connection of upper and under board:

Plug of CON2&CON3 in under board connect with J15 socket of upper board, CN2 FPC of under board connect with CN3 socket of upper board, DSP FPC of under board connect with J30 socket of upper board, make sure all connections are in location and can use silica glue if necessary as right showing:



P21 PSU assembly

7.5 PSU assembly:
Cover the housing after process of
previous page, lock the screws (8pcs) as
below picture showing:

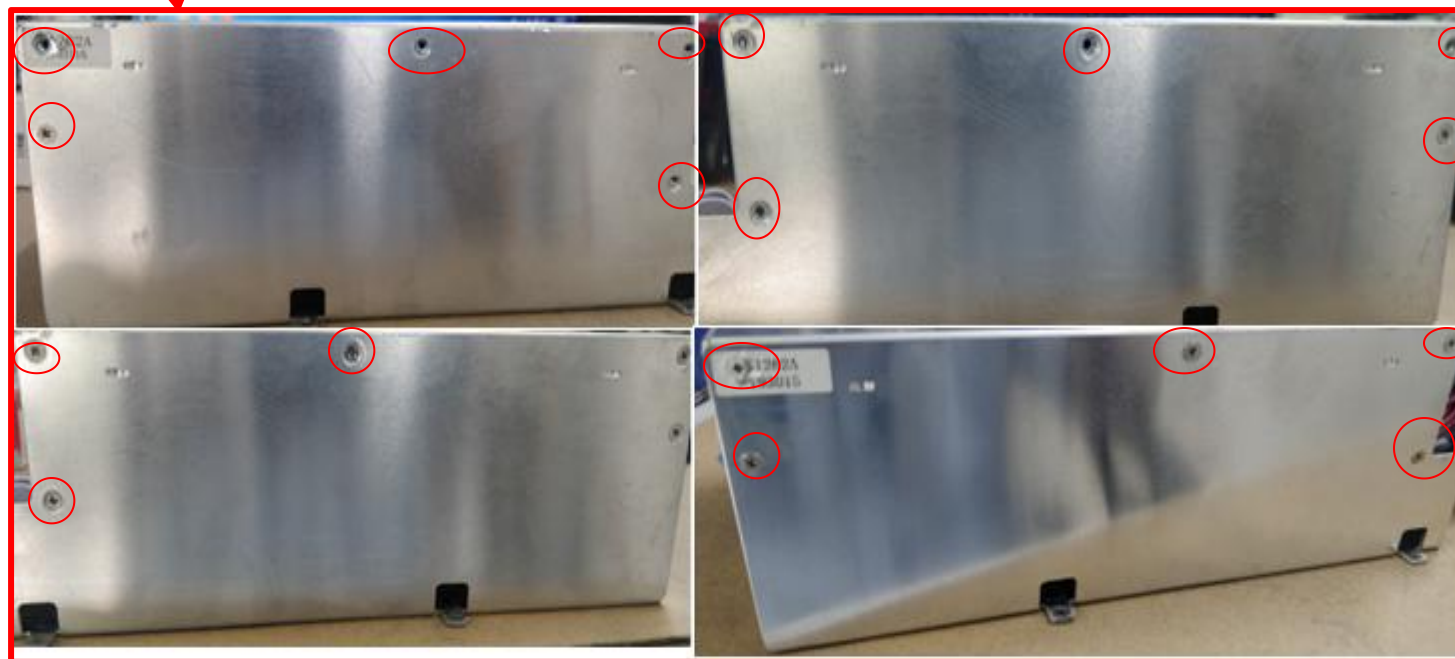

P21 PSU assembly

7.6 PSU
assembly:
P21 PSU
assembly
finished picture
as right
showing:

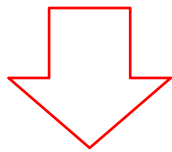

P21D/E PSU assembly

7.7 After above process finished, check whether the cooling fin of PCBA fell off or not, paste them on PCBA as right showing to prevent the PSU from high temperature protection.

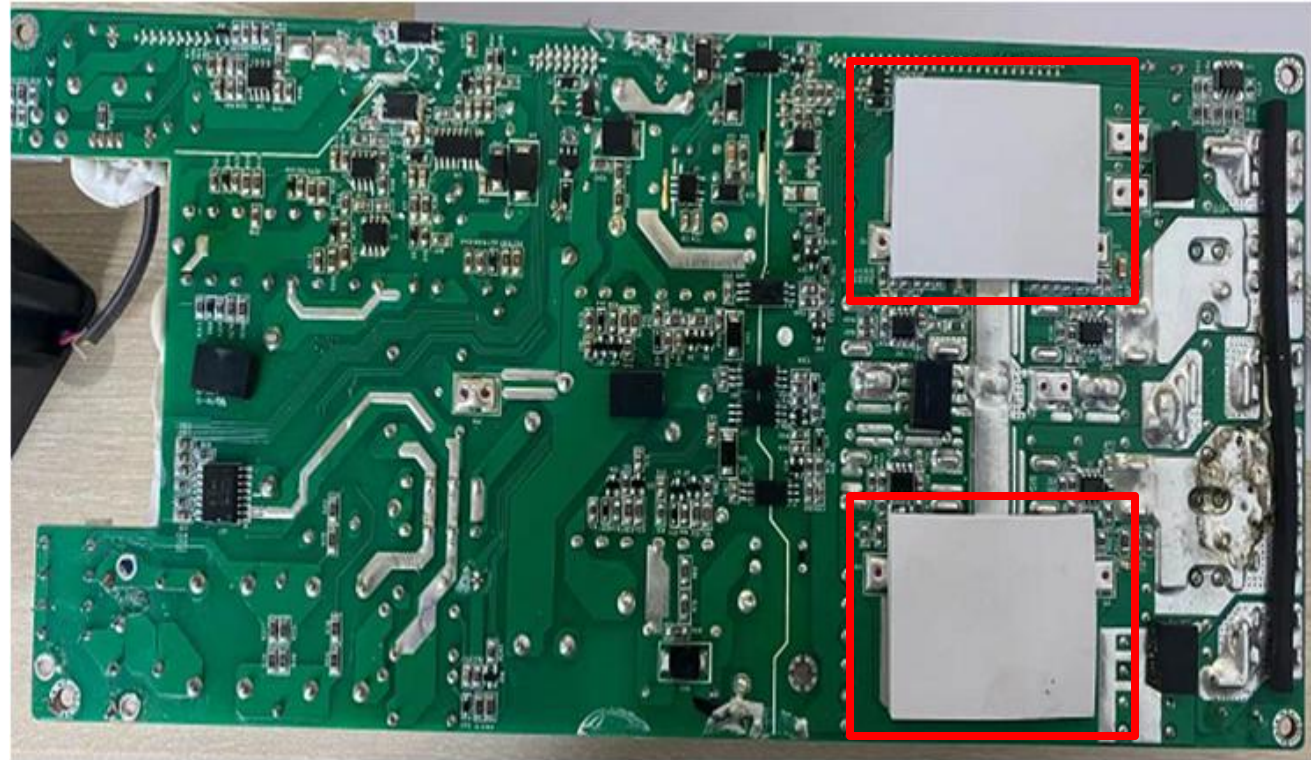
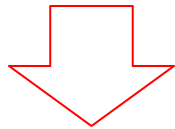

P21D/E PSU assembly

7.9 PSU assembly:
Make sure above process finished, make sure all connections are ok, lock all screws (6pcs) around the surface of PSU as below showing:

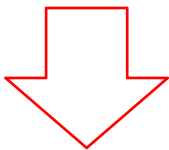
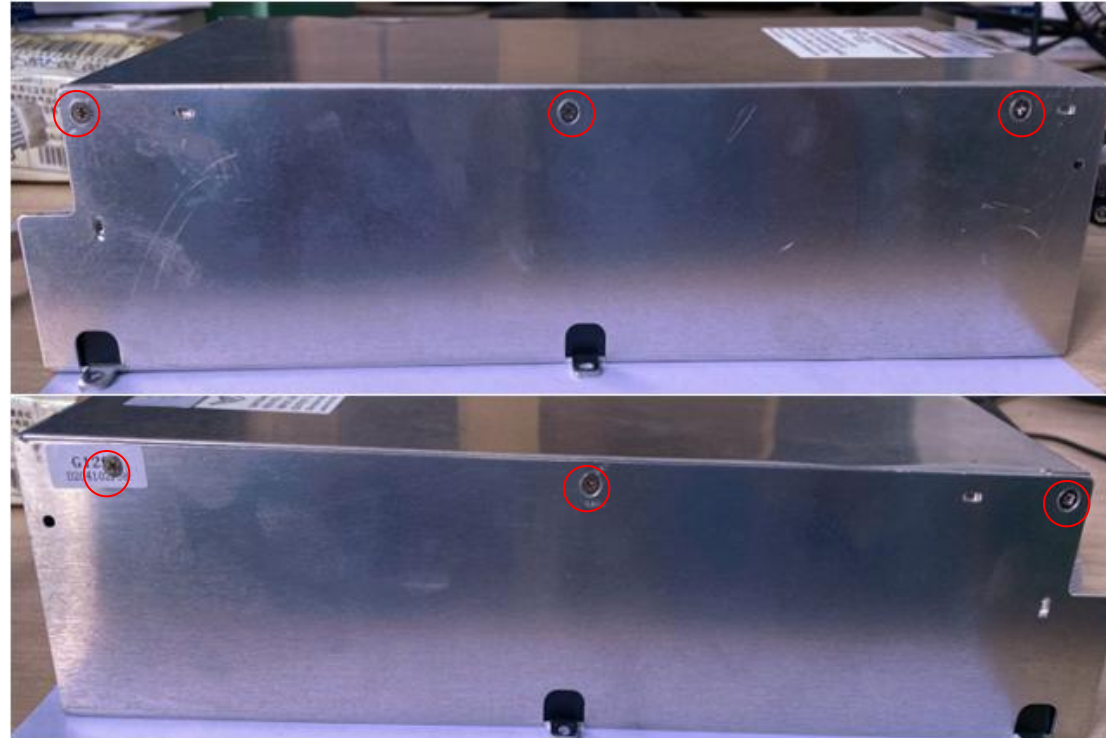

P21D/E PSU assembly

8.0 PSU
assembly:
P21D/E PSU
finished photo
as right
showing:

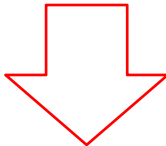

Thank You !